

# Diffuse Scattering

- Anticipatory (trick) question: If you have an x-ray or neutron detector looking at a small sample volume, which will scatter more x-rays or neutrons into the detector 1 atom, 100 atoms or 1000 atoms?

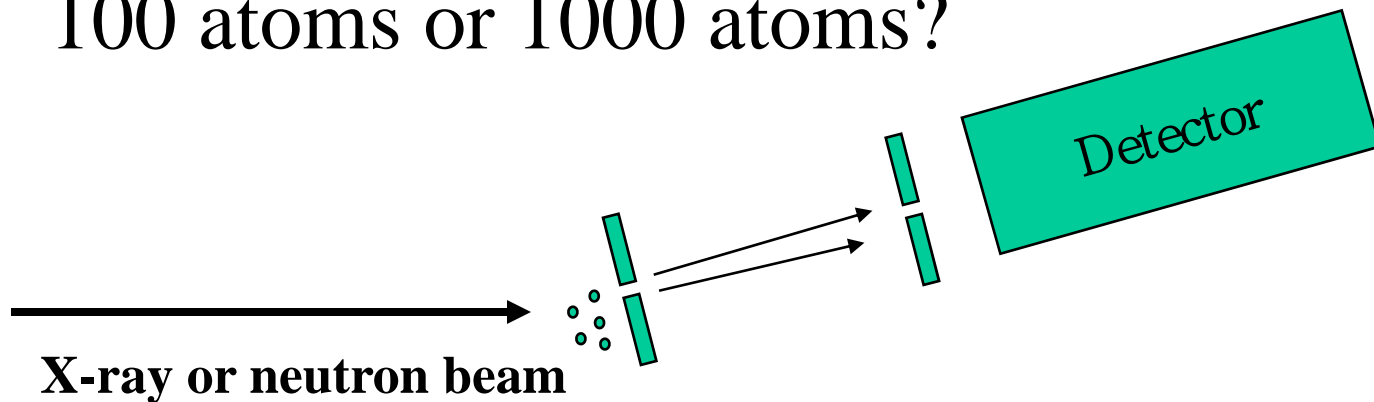

***Answer: Depends!***

# Diffuse Scattering

**Gene E. Ice**

*Materials Science and Technology Division*

*Oak Ridge National Laboratory, USA*

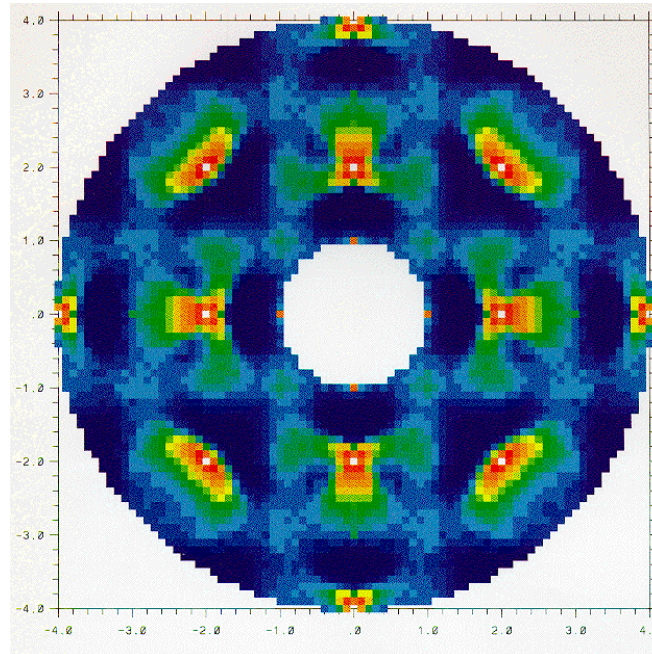

National School on Neutron and X-ray Scattering  
ORNL/SNS June 2009

# Presentation concentrates year graduate-level course into 1 hour

- Skip mathematical complexities
- Expose to range of applications
- Develop *intuition* for length scales
- Talk like x-ray/neutron scattering guru
  - *Reciprocal space*
  - *Debye Temperature*
  - *Laue monotonic*
  - *Krivoglaz defects of 1st/2nd kinds!*



*Great for cocktail parties or impressing attractive strangers*

# Distribution of atoms redistributes scattering

- Familiar light example
- Practical applications- zero background plates for powder diffraction
- Some problems- finding reflections
- Wave→diffraction

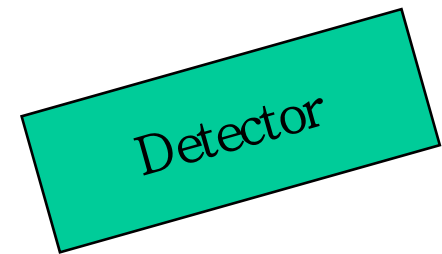
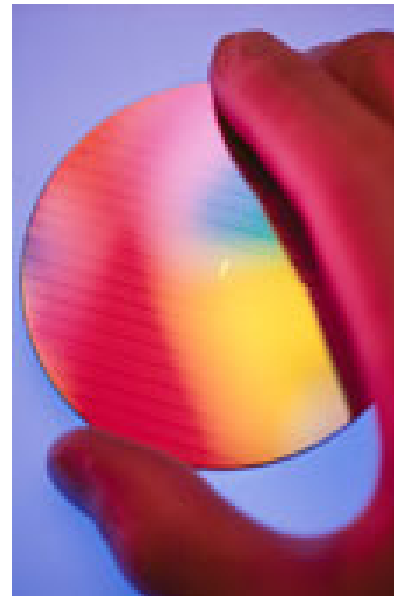
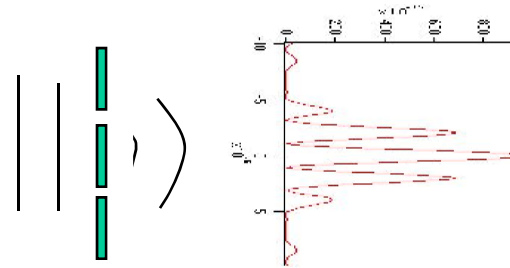

X-ray or neutron beam

# Diffuse scattering poised for a revolution!

- Synchrotron sources /new tools enable new applications
  - Rapid measurements for combinatorial and dynamics
  - High energy for simplified data analysis
  - Small (dangerous) samples
- Advanced neutron instruments emerging
  - Low Z elements
  - Magnetic scattering
  - Different contrast
- New theories provide direct link between experiments and first-principles calculations

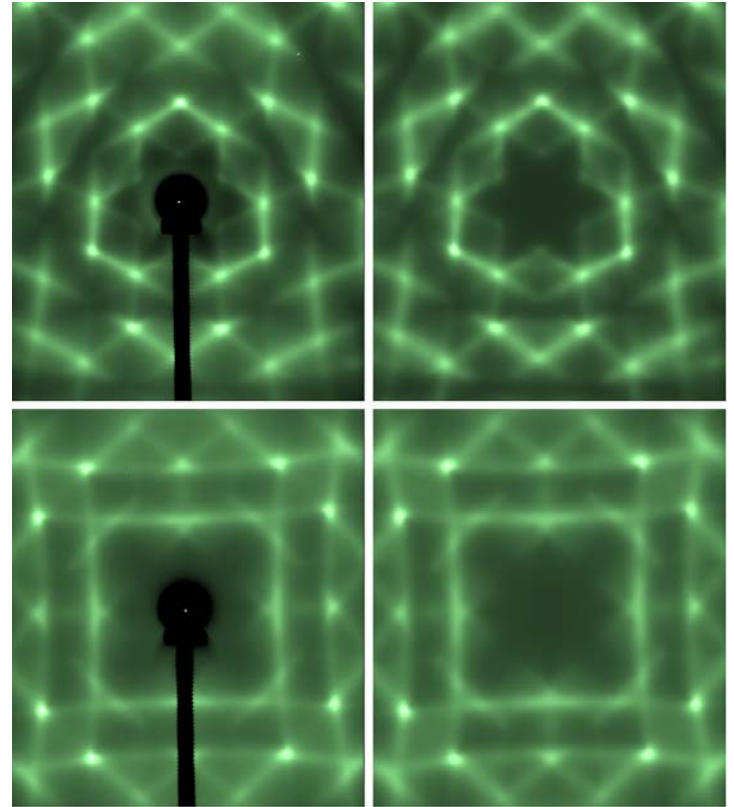

**Experiment**

**Theory**

*Major controversies have split leading scientists in once staid community!*

# Diffuse scattering due to *local* (short ranged) correlations/ fluctuations

- Thermal diffuse scattering (TDS) →

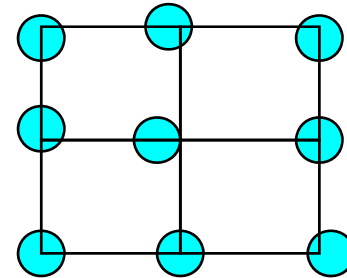

- Point defect

- Site substitution
- Vacancy
- Interstitial

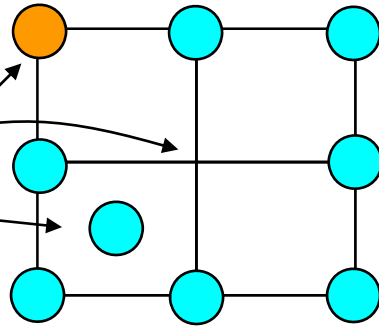

- Precipitate

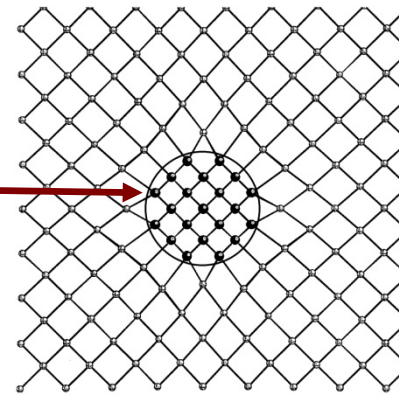

- Dislocations

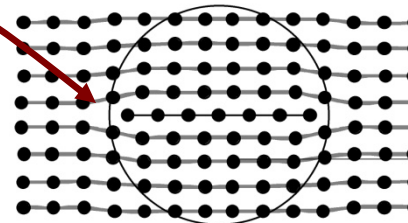

- Truncated surface- more

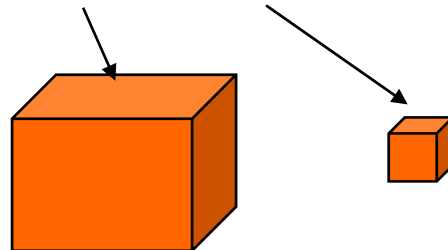

**All have in common reduced correlation length!**

# Bragg reflection occurs when scattering amplitudes add *constructively*

- Orientation of sample
- Wavelength
- Bragg Peaks sharp!  $\sim 1/N$  (arc seconds)

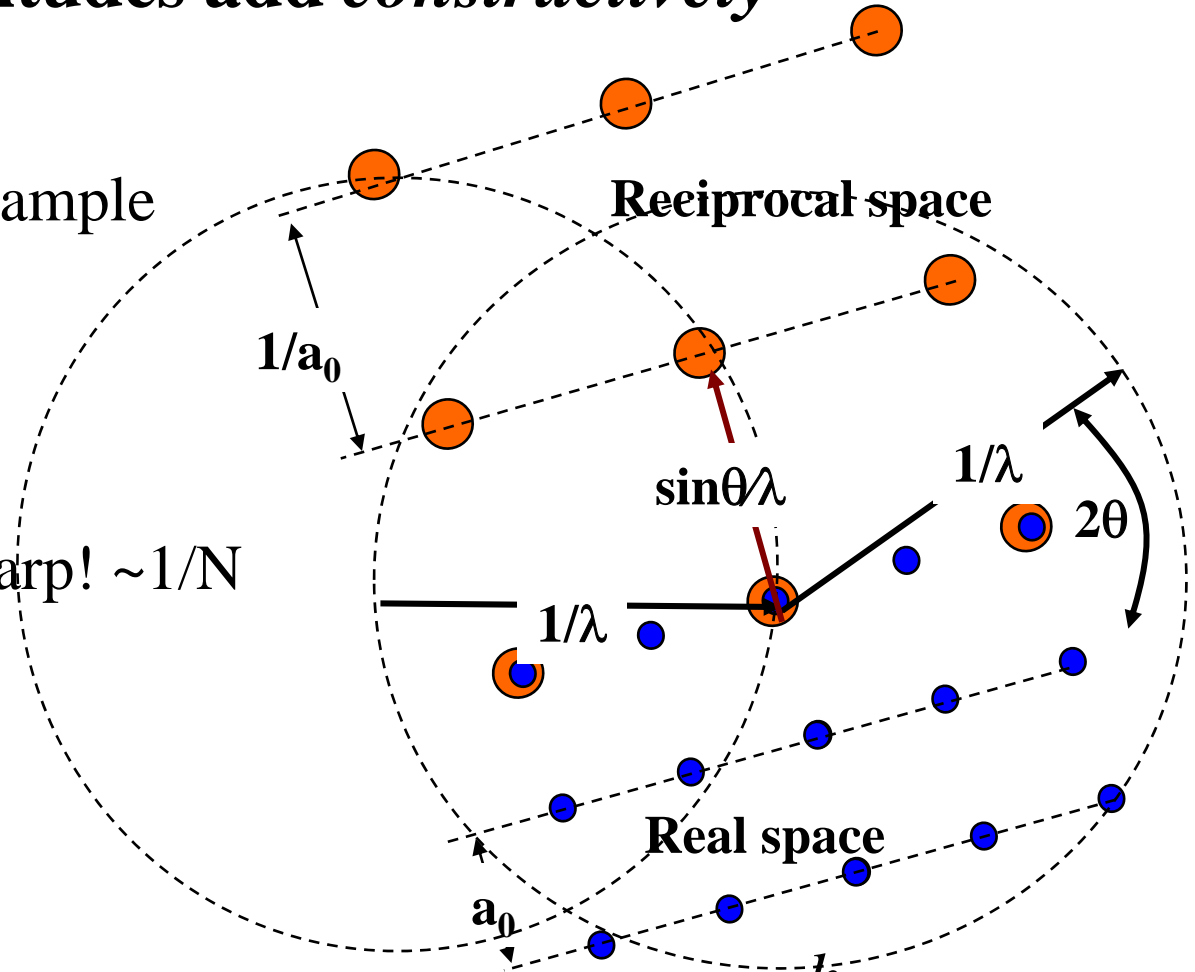

Think in terms of *momentum transfer*  $\bar{p}_0 = \frac{h}{\lambda} \hat{d}_0$

# Length scales

- Big real  $\rightarrow$  small reciprocal
- Small real  $\rightarrow$  big reciprocal
- *We will see same effect in correlation length scales*
  - Long real-space correlation lengths scattering close to Bragg peaks

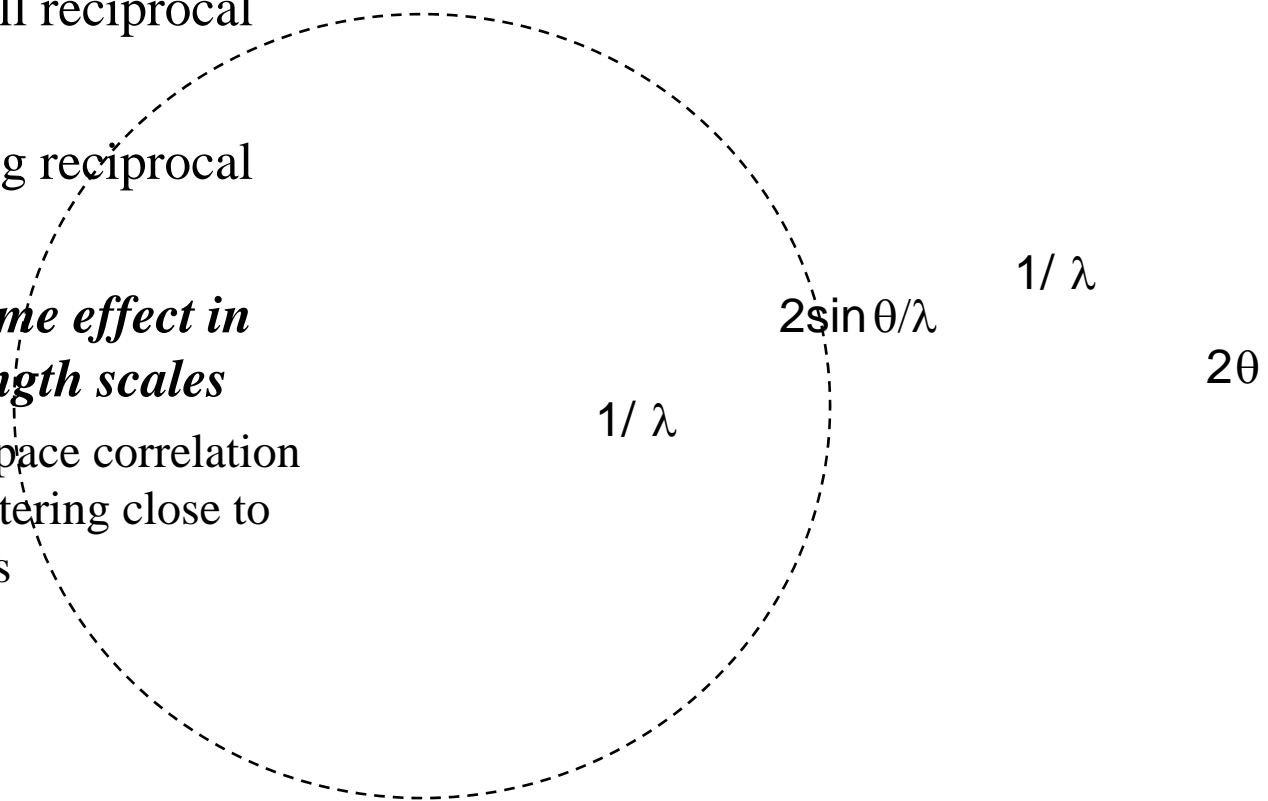

*If you remember nothing else!*



# Krivoglaz classified defects by effect on Bragg Peak

- **Defects of 1st kind**

- Bragg width unchanged
- Bragg intensity decreased
- Diffuse redistributed in reciprocal space
- Displacements remain finite

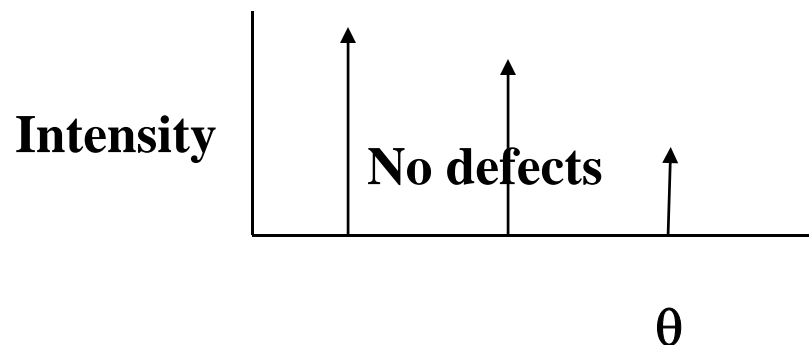

- **Defects of 2nd kind**

- No longer distinct Bragg peaks
- Displacements continue to grow with crystal size

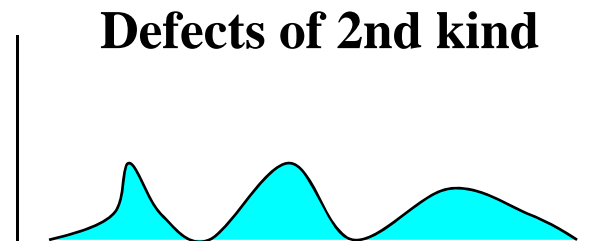

# Dimensionality influences diffraction

- **Small size**→**broad diffraction**

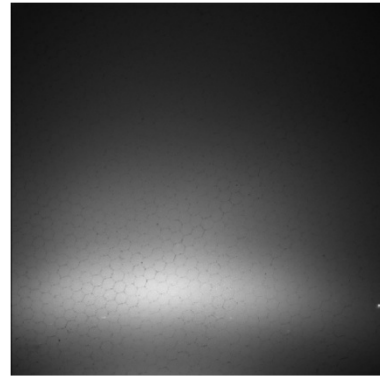

a. Amorphous

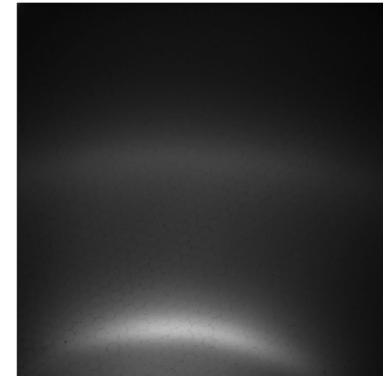

b. nanocrystalline

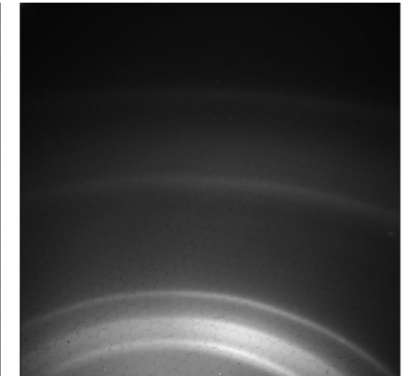

c. crystalline

- **Polycrystalline**



- **Single crystalline (roughness)**

QuickTime™ and a TIFF (Uncompressed) decompressor are needed to see this picture.



# Thermal motion-Temperature Diffuse Scattering- (TDS) -defect of 1st kind

- Atoms coupled through atomic bonding
- Uncorrelated displacements at distant sites
  - (finite)
- Phonons (wave description)
  - Amplitude
  - Period
  - Propagation direction
  - Polarization (transverse/compressional)

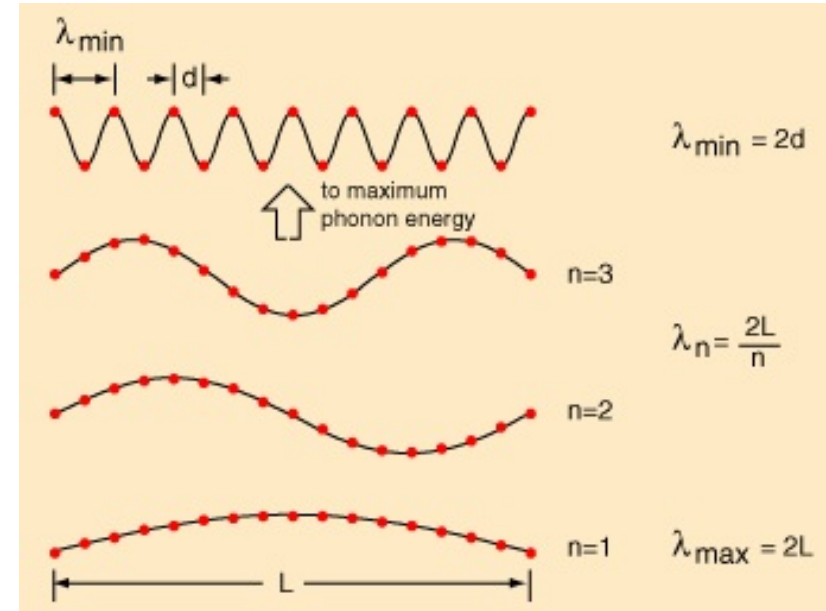
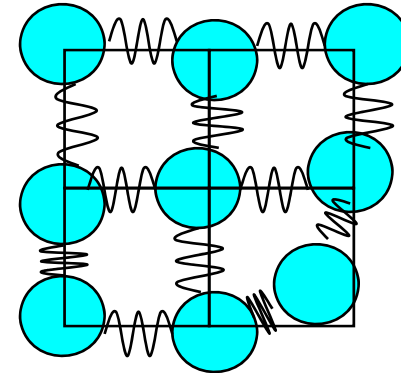

**Sophisticated theories from  
James, Born Von Karmen, Krivoglaz**

# A little math helps for party conversation

- Decrease in Bragg intensity scales like  $e^{-2M}$ , where

$$2M = 16\pi^2 \langle u_s^2 \rangle \frac{\sin^2 \theta}{\lambda^2}$$

- *Small*  $\theta \rightarrow$  *Big* reflections
- $e^{-2M}$  shrinks (*bigger* effect) with  $\theta$  (q)

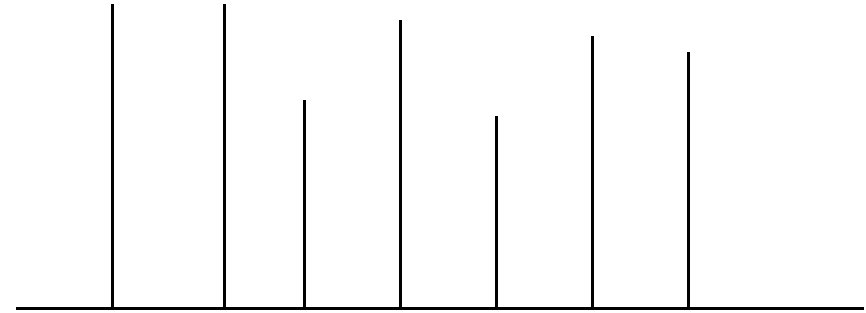

**Low Temperature**

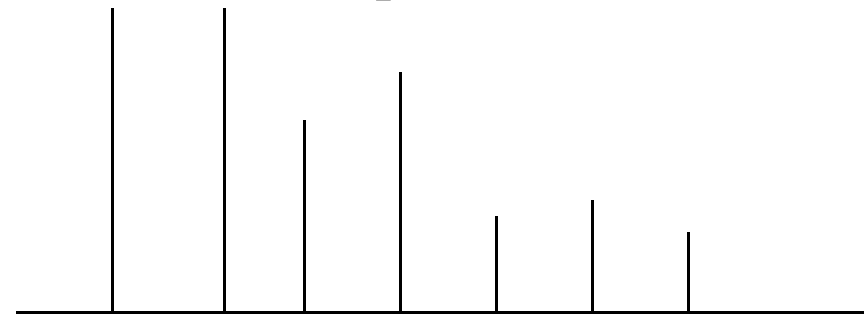

**High temperature**

Displacements,  $u_s$  depend on *Debye Temperature*  $\theta_D$  - *Bigger*  $\theta_D \rightarrow$  *smaller* displacements !

# TDS makes beautiful patterns reciprocal space

- Iso- intensity contours
  - Butterfly
  - Ovoid
  - Star
- Transmission images reflect symmetry of reciprocal space and TDS patterns

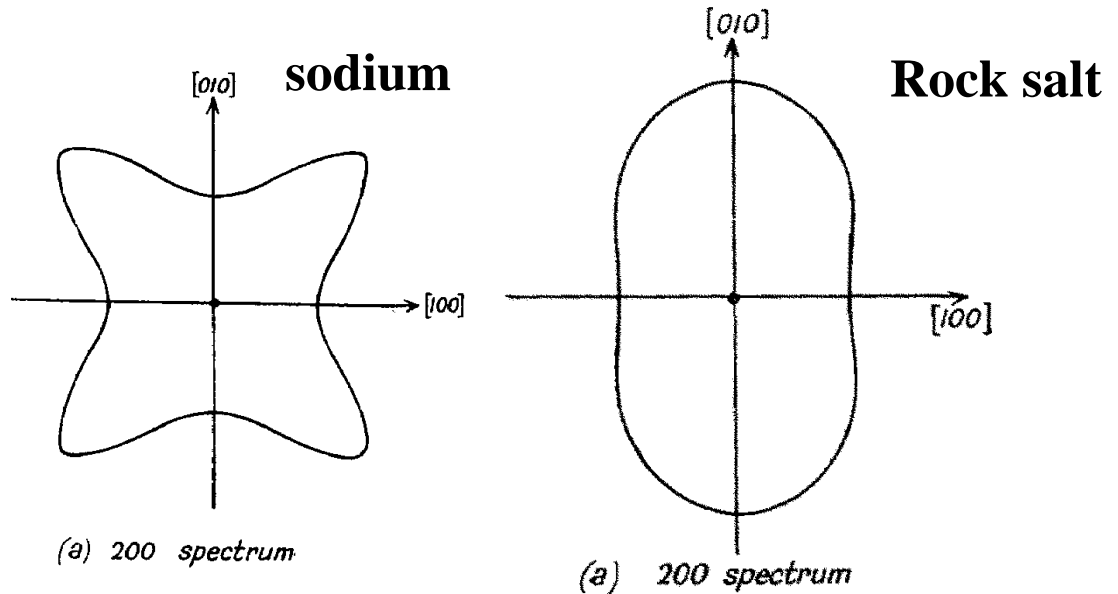

**Experiment**

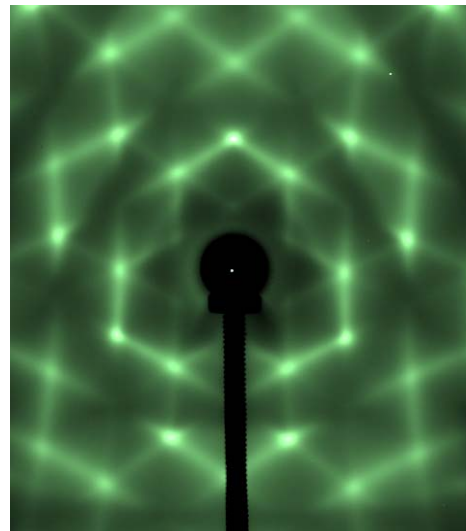

**Theory**

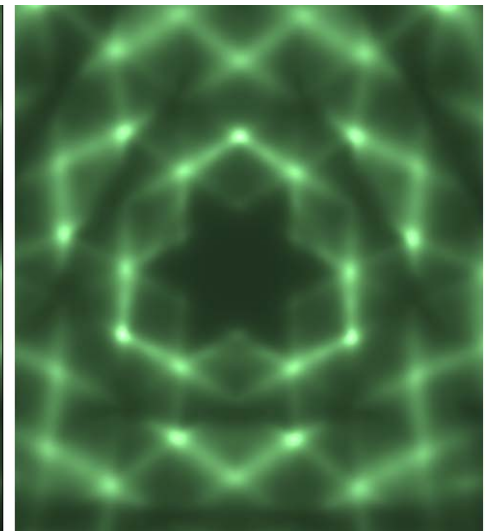

**Chiang et al. Phys. Rev. Lett.  
83 3317 (1999)**

# X-rays *scattering* measurements *infer* phonon dispersion from quasi-elastic scattering

- Phonon energies *milli-eV*
- Synchrotron based high-E resolution X-ray beamlines can measure phonons *in some cases*
- Emerging area for high-brilliance x-ray sources

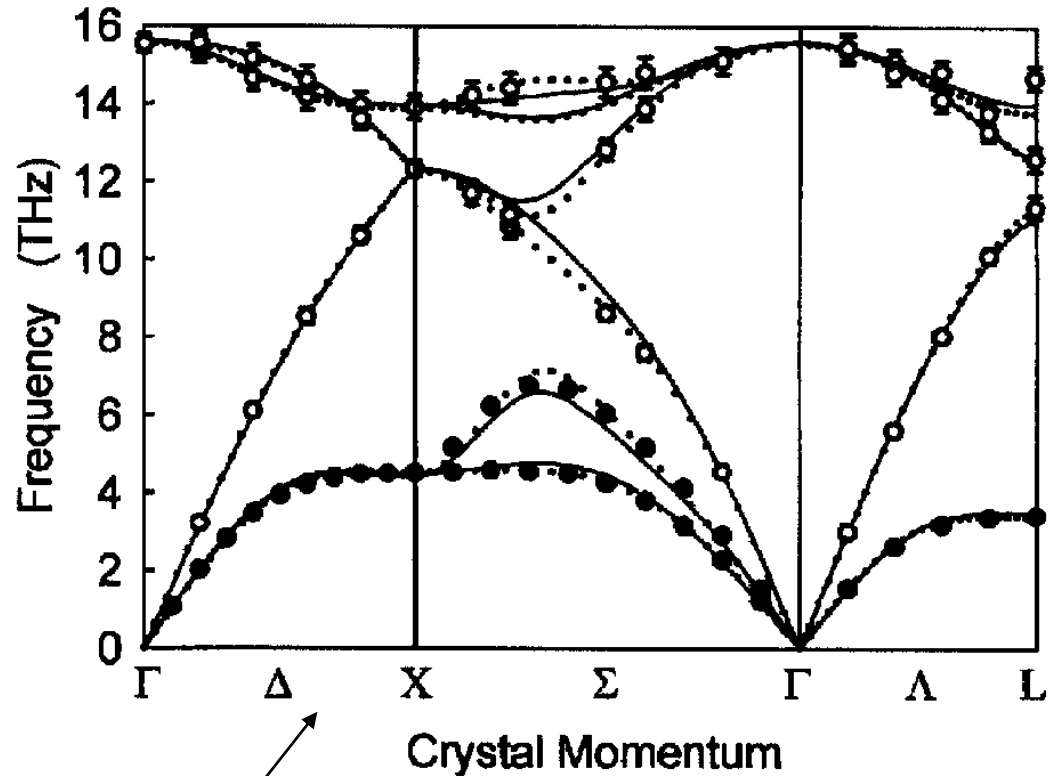

Phonon spectrum gives natural vibration frequencies in different crystal directions!

# Inelastic neutron/x-ray scattering directly measures phonon spectra in symmetry directions

- Inelastic neutron scattering confirms origins of negative Grüneisen coefficient in cubic  $\text{ZrW}_2\text{O}_8$  (negative thermal expansion)-disordering phase transition.
- Unusual thermal displacements *often associated with phase transitions.*

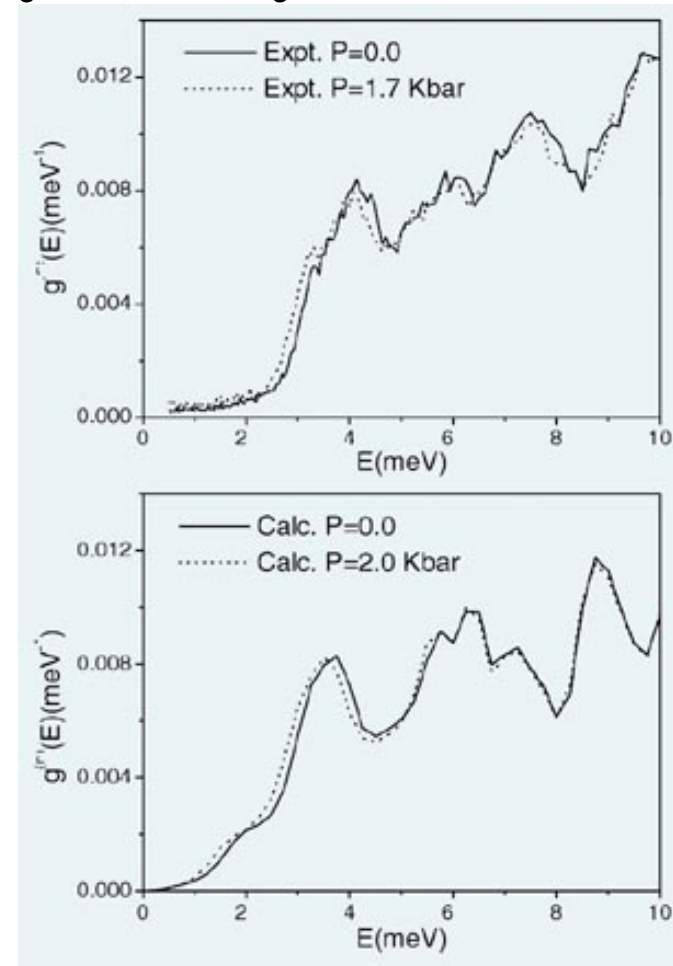

*Phonon energies similar to meV neutron energies.*

# Diffuse scattering near phase transitions

- **Distribution of configurations at finite temperature**
  - Mixed phases (1st order)
- **Extended displacements**
- **High-pressure**
  - higher-co-ordination
  - Longer NN bond distance
  - Smaller volume/atom

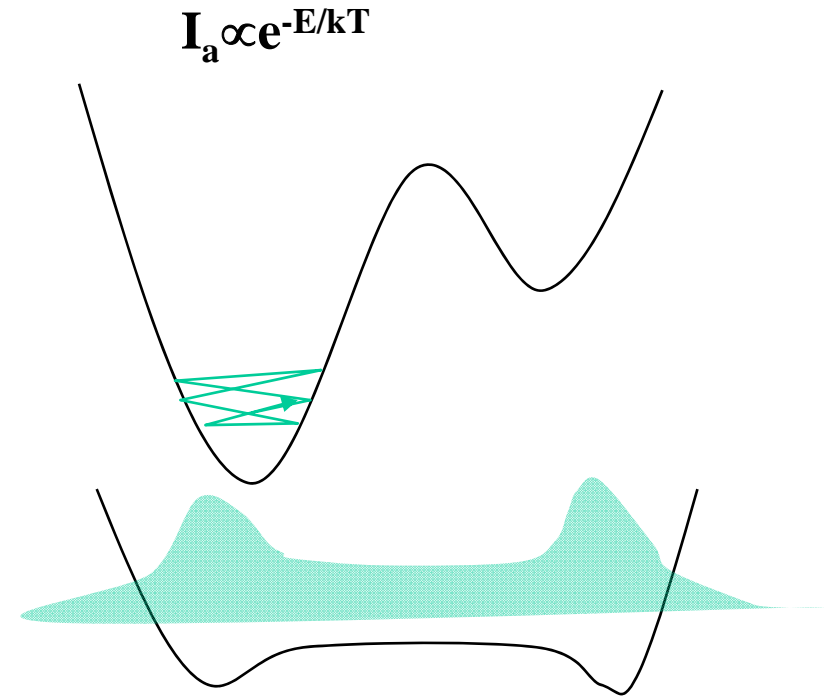



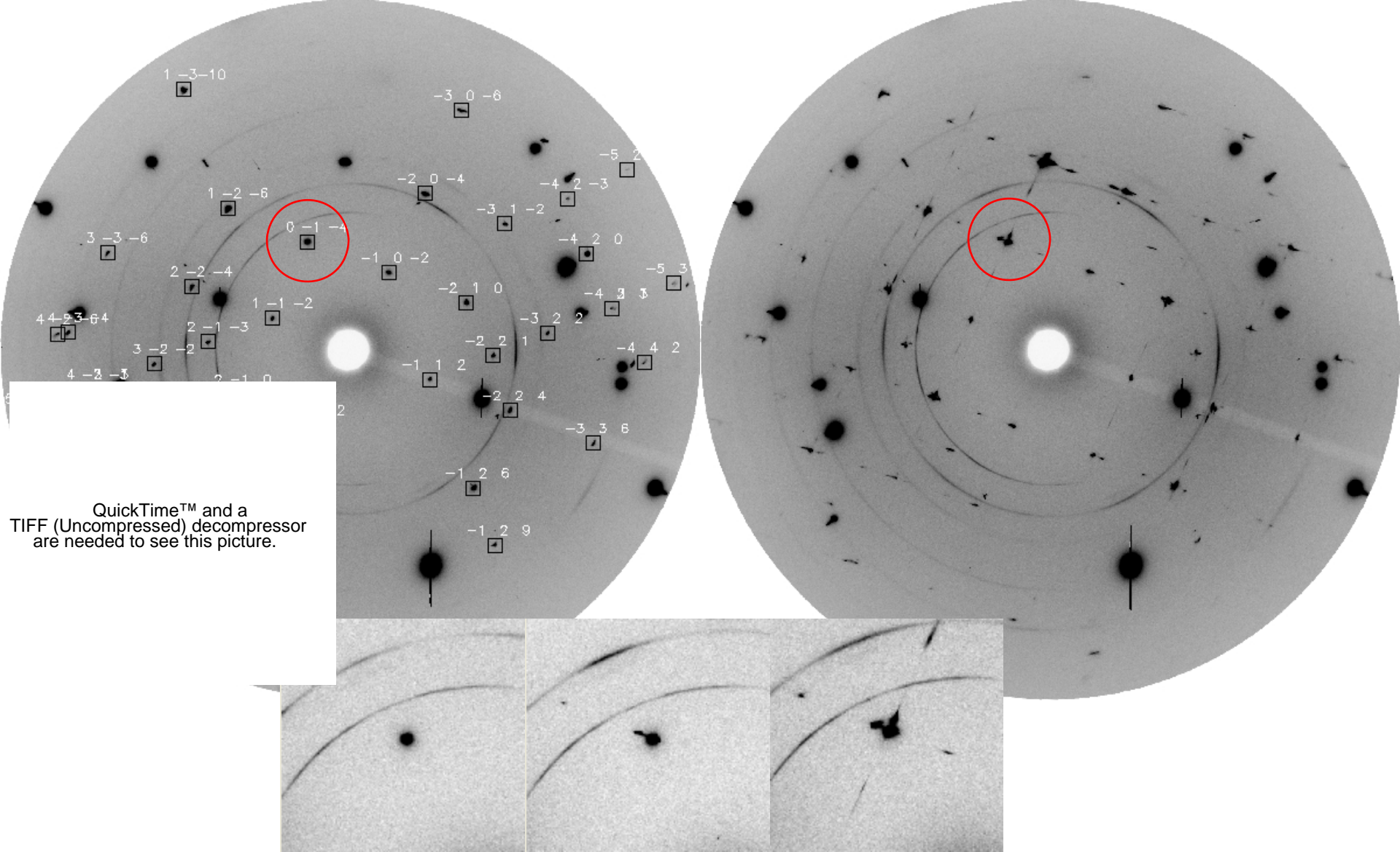

R-3c $\rightarrow$ I2/a displacive transition observed in a single crystal of  $\text{Cr}_2\text{O}_3$  at 80 GPa

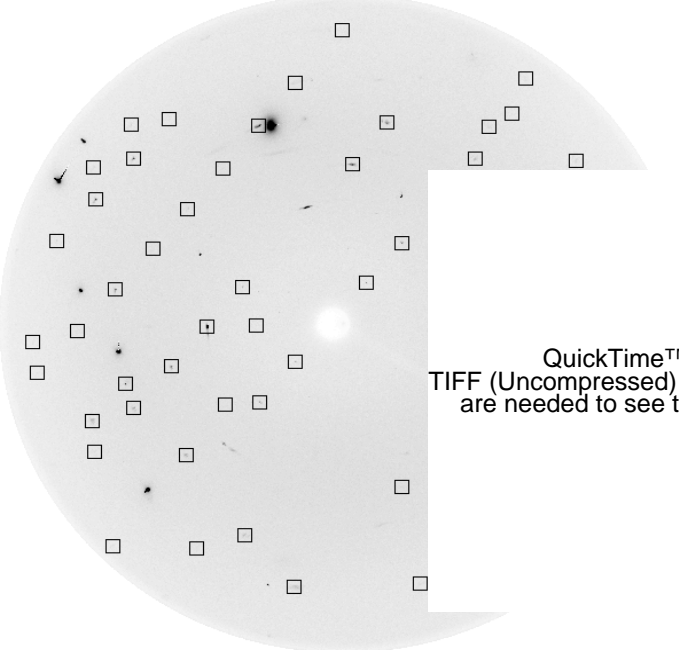

QuickTime™ and a  
TIFF (Uncompressed) decompressor  
are needed to see this picture.

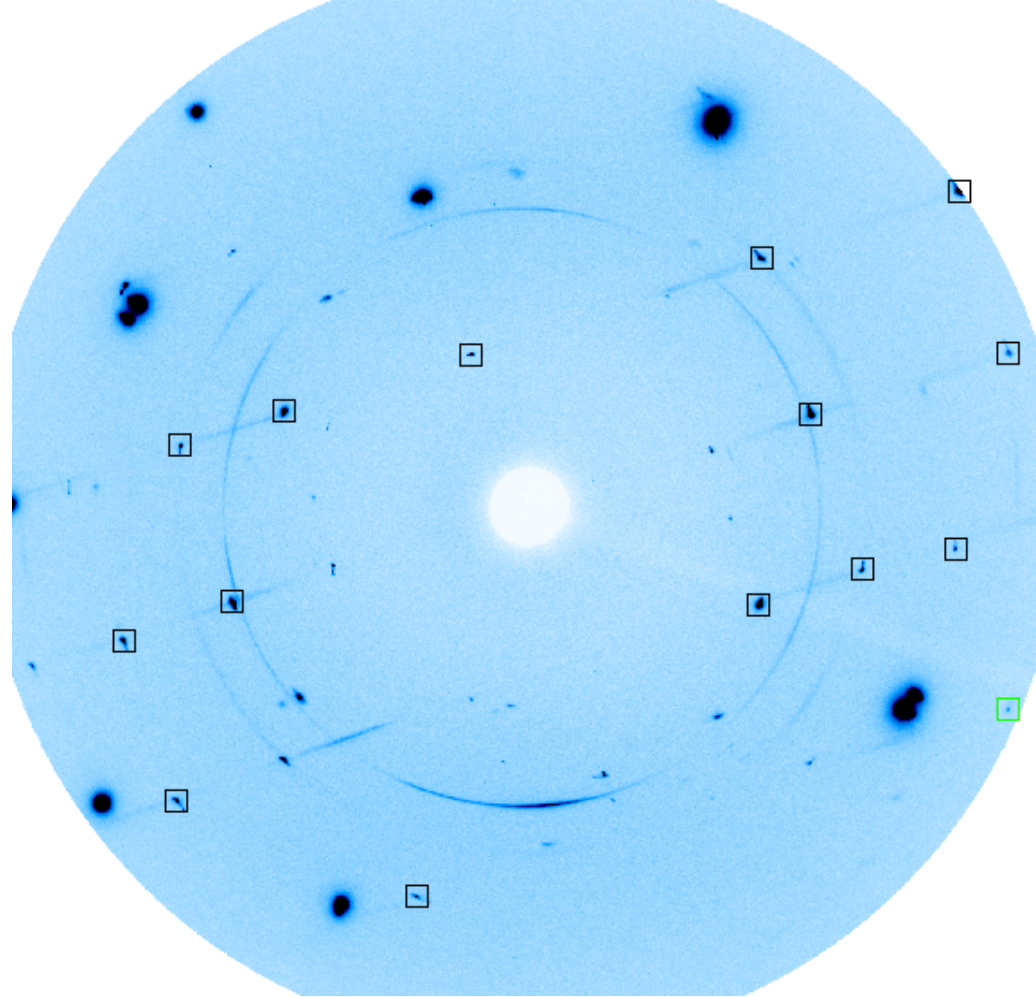
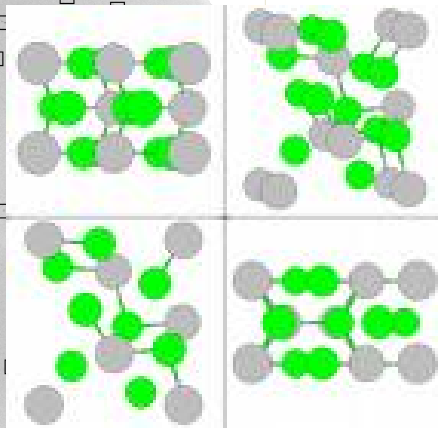
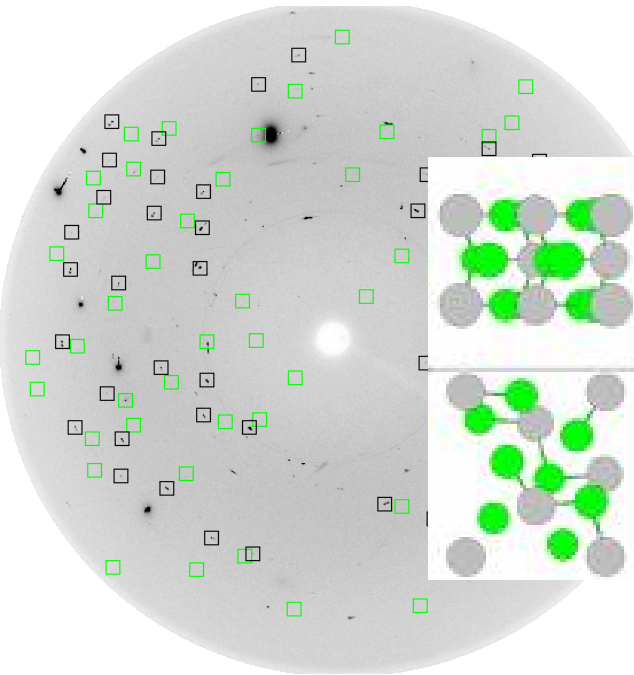

Diffuse scattering before the transformation occurs, heating at ~1000 K

C22 → C23 transition in Fe<sub>2</sub>P at 10 GPa  
Dera et al. (2008) *Gophys. Res. Lett.*, **35**, L10301

Complete transformation induced by heating the sample to 2000 K

# High-energy Synchrotron X-rays are revolutionizing TDS measurements

- Small samples
- Fast (time resolved/combinatorial)
  - Experiments in seconds rather than days
- Materials that cannot be studied with neutrons

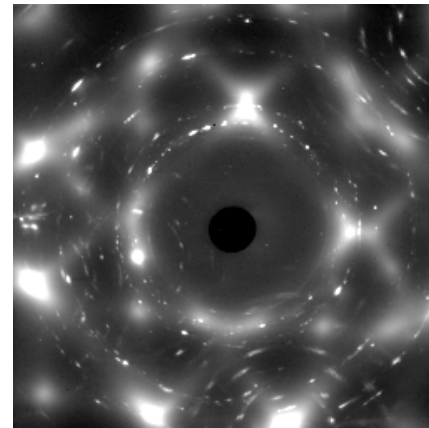
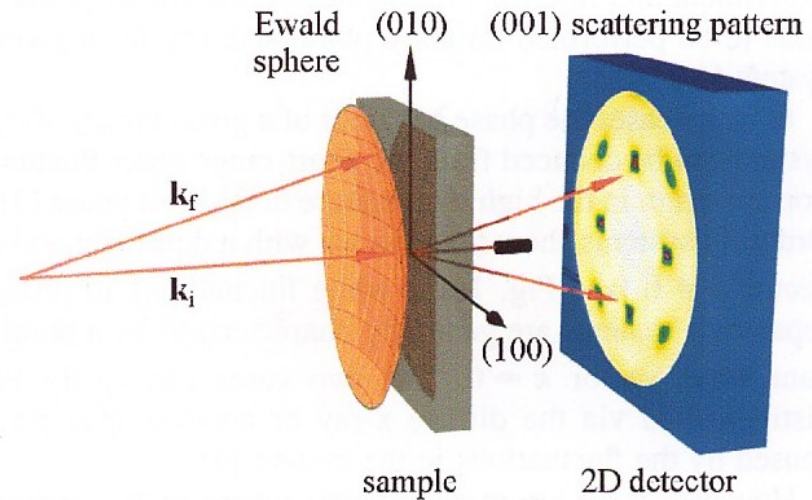

**Pu experiment**

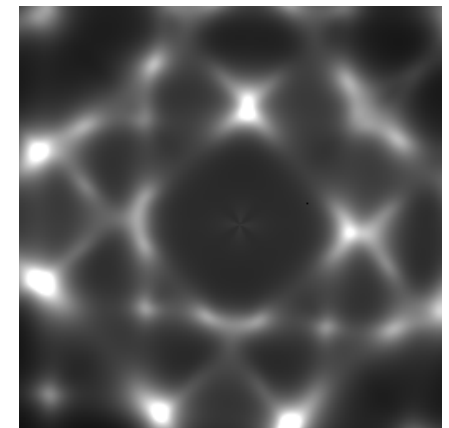

**Pu theory**



# Neutrons uniquely sensitive to low Z

- Deuterium cross section large
- Phonon energy comparable to neutron energy
- New instruments will accelerate data collection

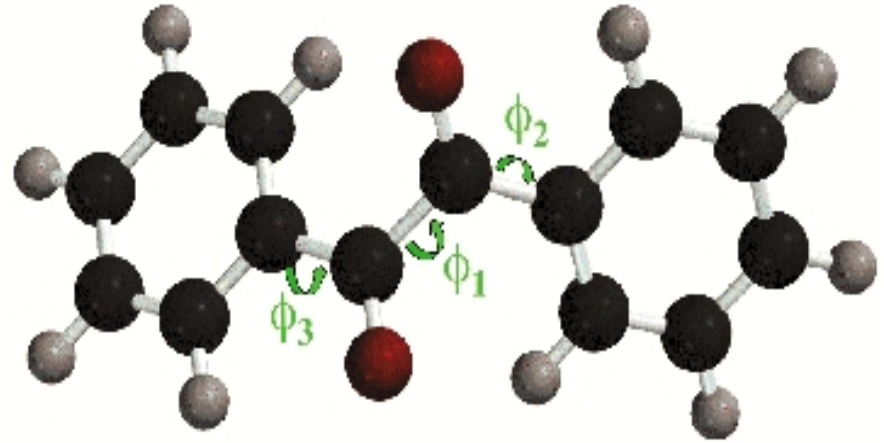

splitting

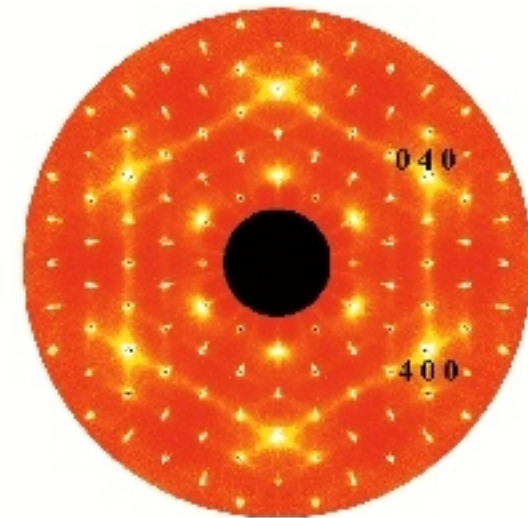
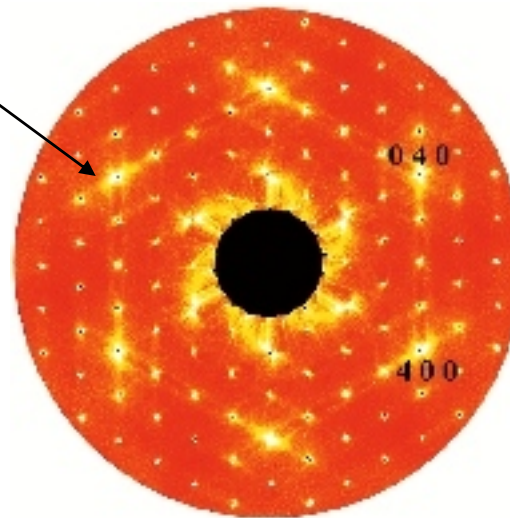

Welberry et al. ISIS

Experiment

Theory

# Often TDS mixed with additional diffuse scattering

- Experiment

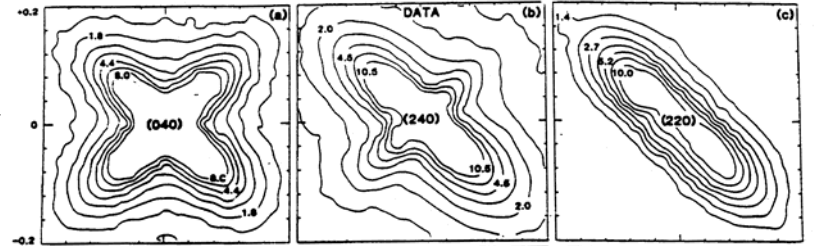

- Strain contribution



$$\Delta k \left[ \frac{2\pi}{a} \right]$$

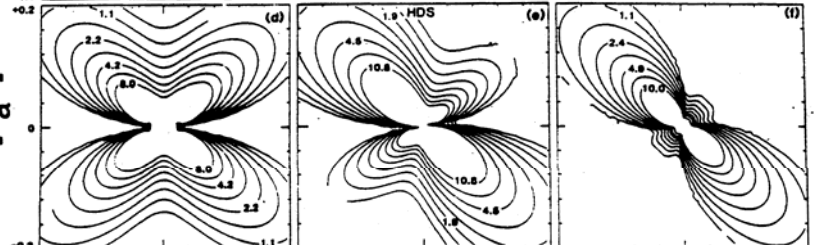

- Combined theoretical TDS and strain diffuse scattering

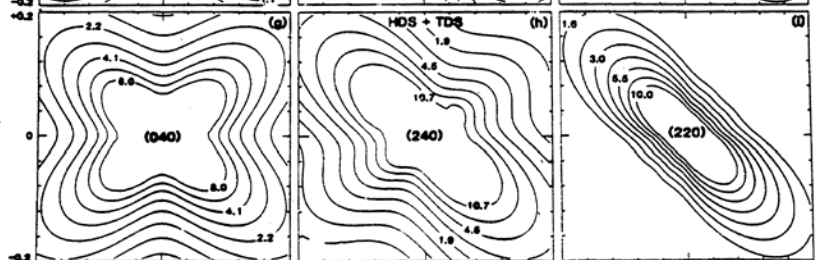

$$\Delta h \left[ \frac{2\pi}{a} \right]$$

TDS must often be removed to reveal other diffuse scattering

# Alloys can have another *type 1* defect-site substitution

- Long range
  - Ordering (unlike neighbors)
  - Phase separation (like neighbors)

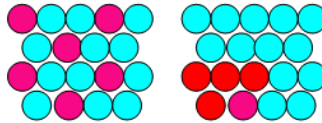

- Short ranged
  - Ordering
  - Clustering (like neighbors)

Each Au has 8 Cu near-neighbors

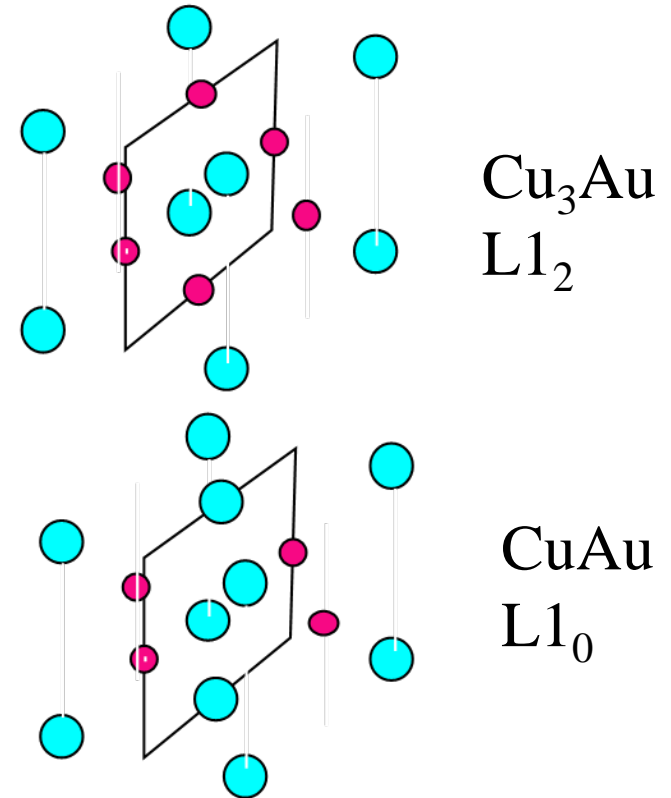

Alternating planes of Au and Cu

# Redistribution depends on kind of correlation

Clustering intensity  
→ fundamental sites

Random causes  
*Laue monotonic*

Short-range ordering  
→ superstructure sites

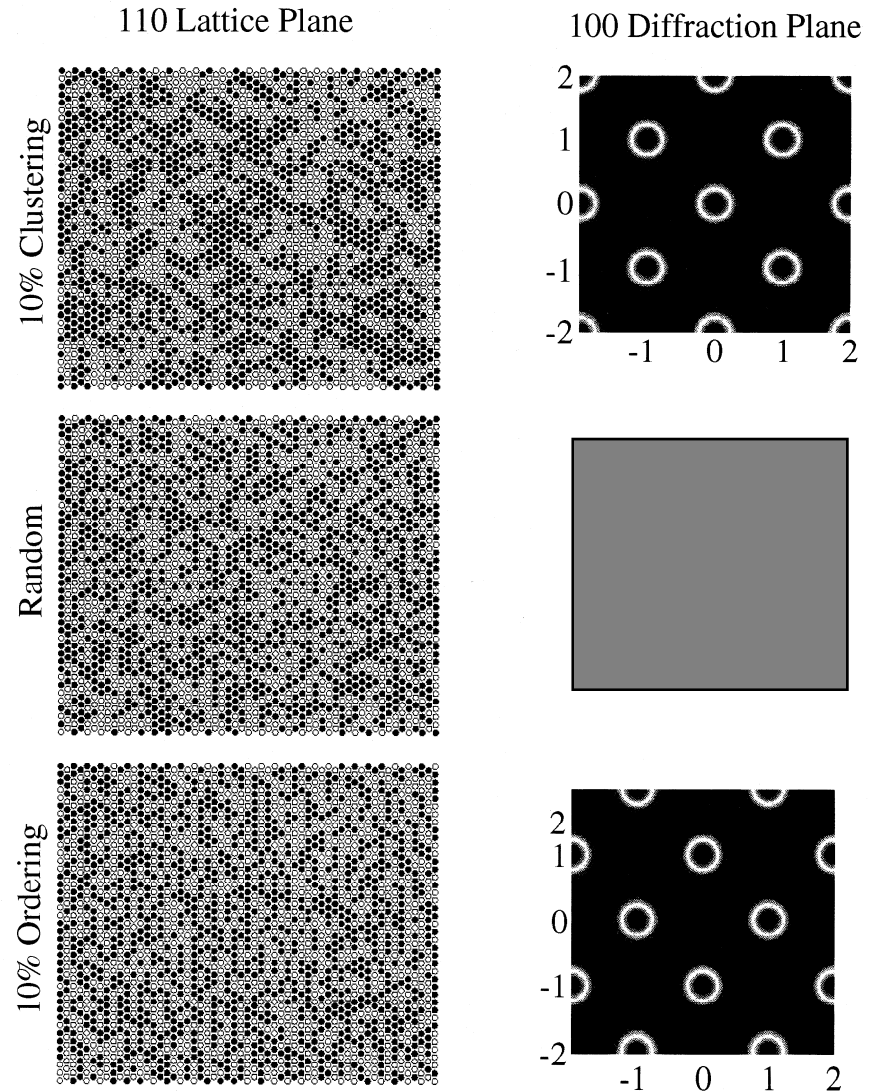

# Neutron/ X-rays Complimentary For Short-range Order Measurements

- Chemical order diffuse scattering **proportional to contrast  $(f_A - f_B)^2$**
- Neutron scattering cross sections
  - Vary wildly with isotope
  - Can have + and - sign
  - Null matrix
  - Low Z , high Z comparable
- X-ray scattering cross section
  - Monotonic like  $Z^2$
  - Alter by anomalous scattering

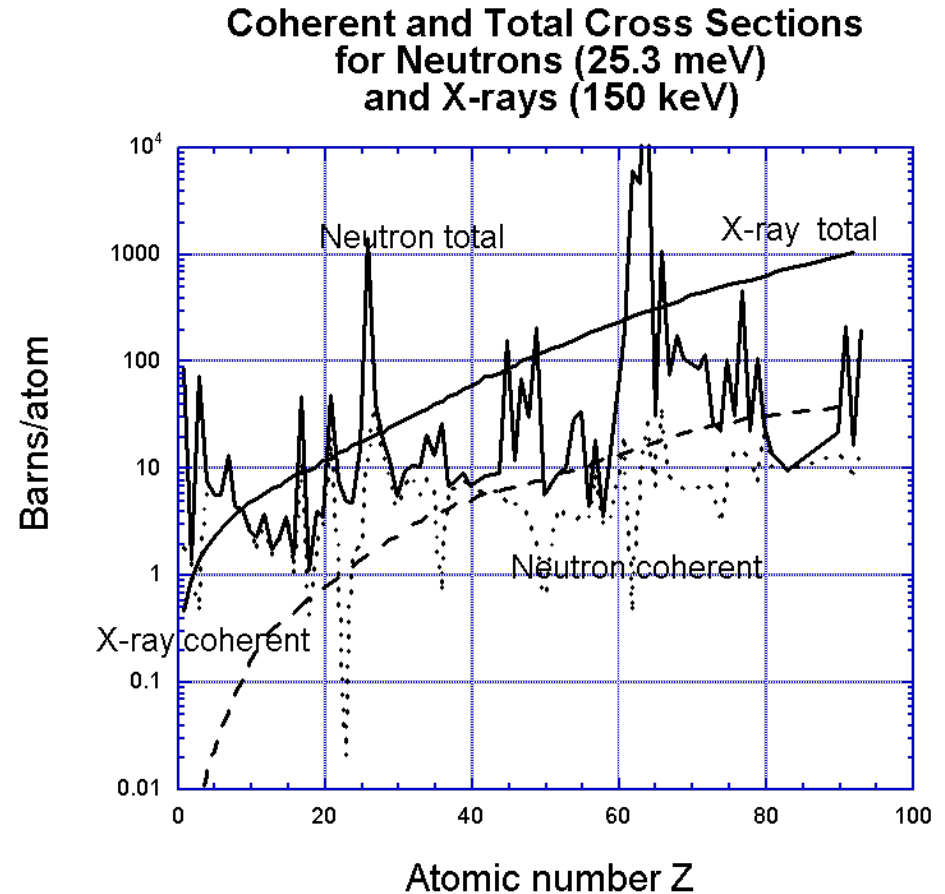



# Neutrons can select isotope to eliminate Bragg scattering

- Total scattering  $c_a f_a^2 + c_b f_b^2 = 3$

- Bragg scattering  $(c_a f_a + c_b f_b)^2 = 0$

- Laue (diffuse) scattering  $c_a c_b (f_a - f_b)^2 = 3$

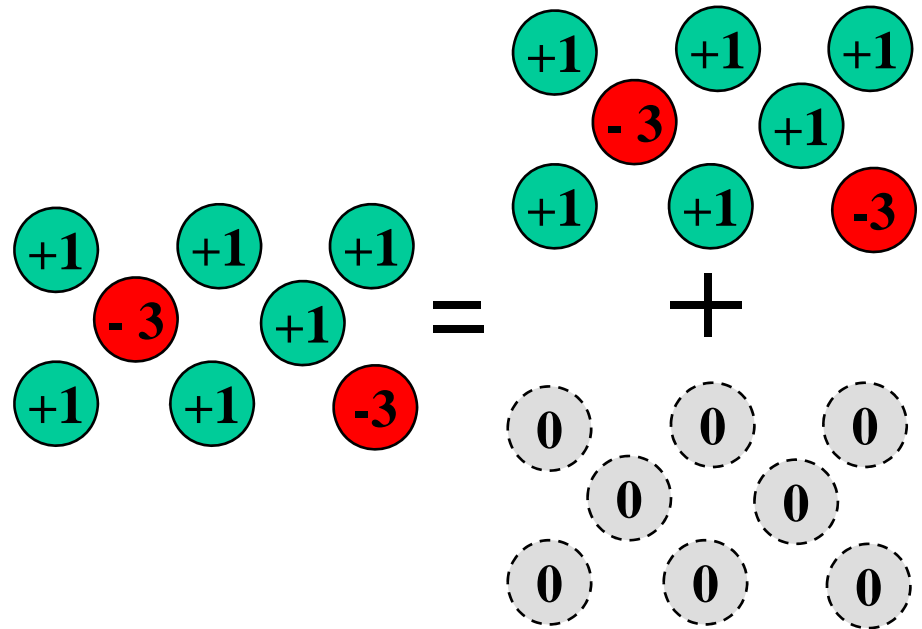

*Isotopic purity important as different isotopes have distinct scattering cross sections- only one experiment ever done!*

# X-ray anomalous scattering can change x-ray contrast

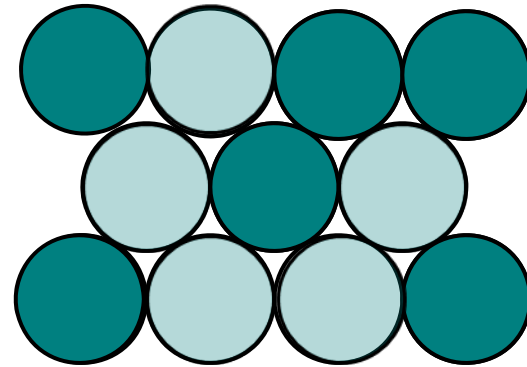
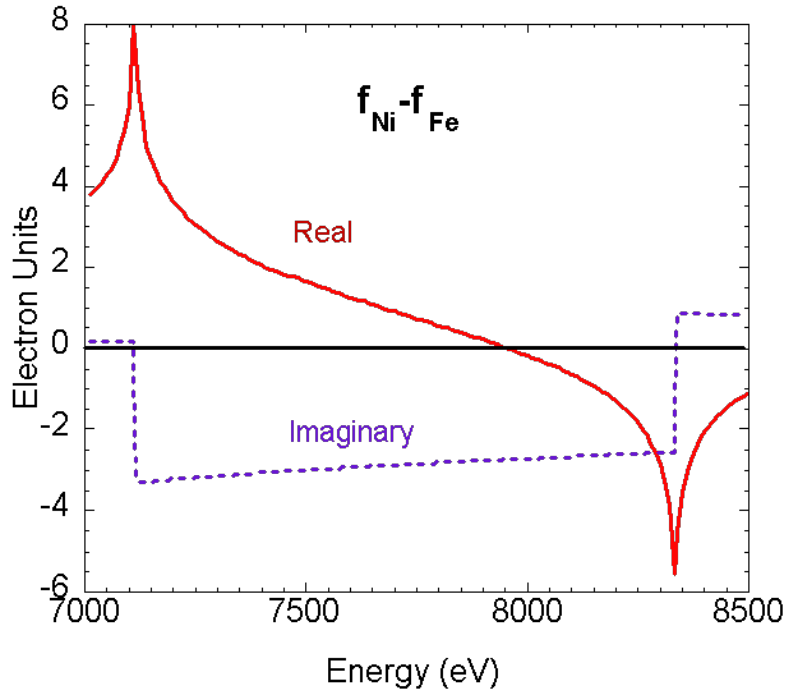

- Chemical SRO scattering scales like  $(f_a - f_b)^2$
- Static displacements scale like  $(f_a - f_b)$
- TDS scales like  $\sim f_{\text{average}}^2$

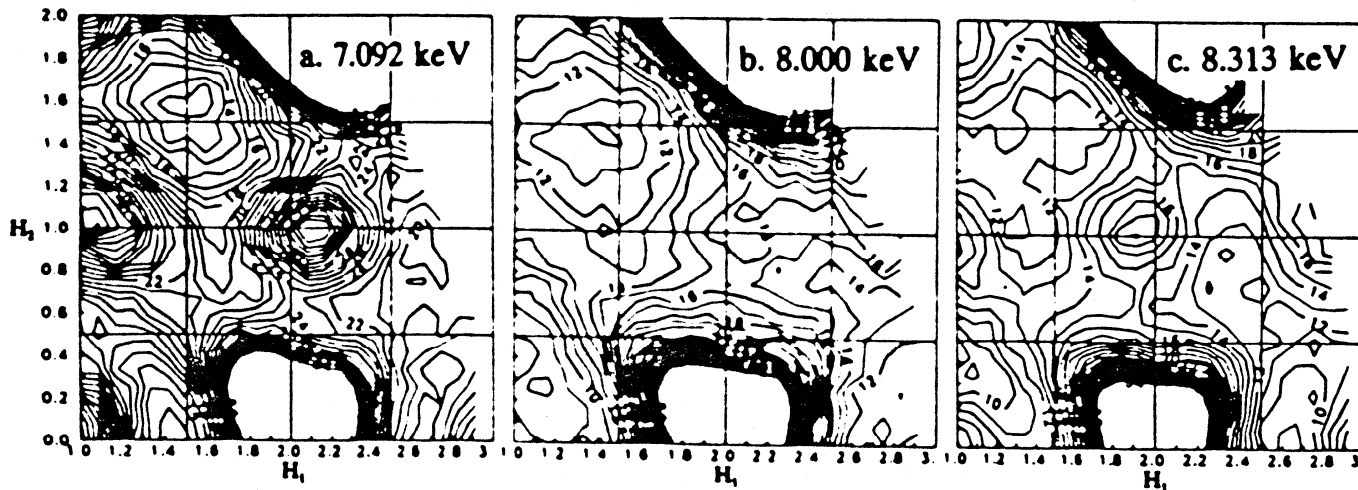

# Atomic size (static displacements) affect phase stability/properties

- *Ionic materials (Goldschmidt)*
  - Ratio of Components
  - **Ratio of radii**
  - Influence of polarization
- *Metals and alloy phases (hume-Rothery)*
  - **Ratio of radii**
  - Valence electron concentration
  - Electrochemical factor

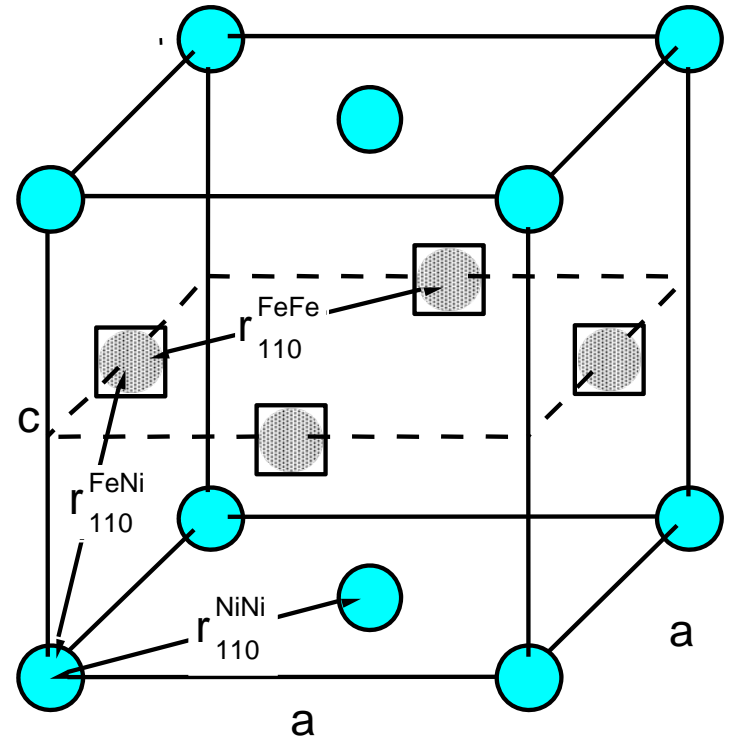

***Grand challenge -include deviations from lattice in modeling of alloys***

# Measurement *and* theory of atomic size are hard!

- Theory- violates repeat lattice approximation- every unit cell different!

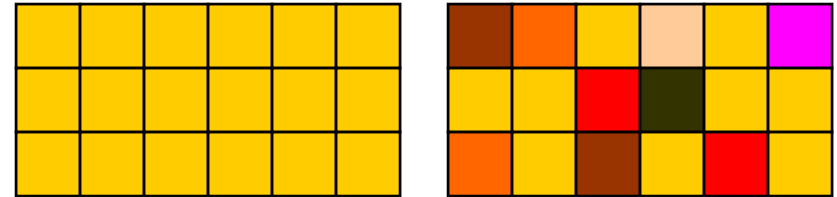

- Experiment
  - EXAFS marginal (0.02 nm) in dilute samples
  - Long-ranged samples have balanced forces

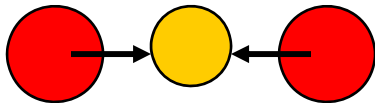

**Important!**

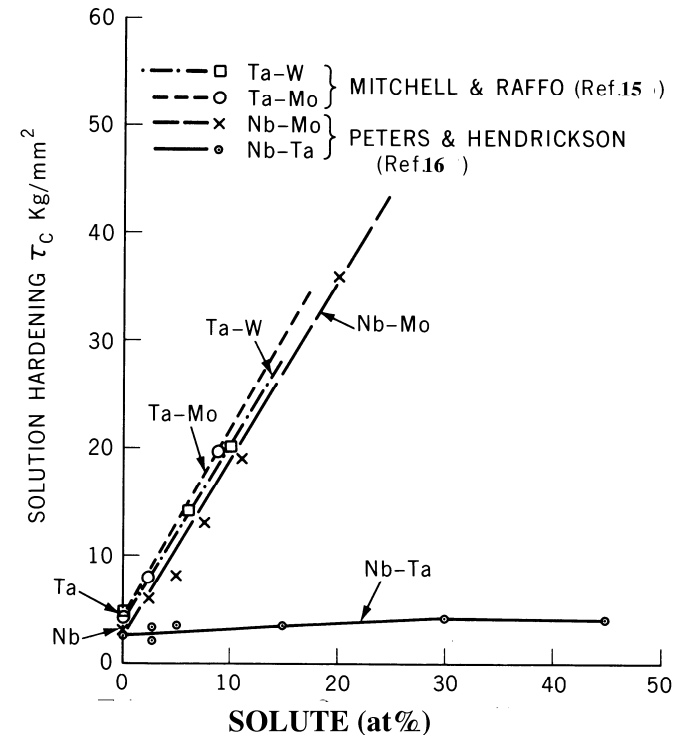

# Systematic study of bond distances in Fe-Ni alloys raises interesting questions

ORNL 98-7348A/rra

- Why is the Fe-Fe bond distance stable?
- Why does Ni-Ni bond swell with Fe concentration?
- Are second near neighbor bond distances determined by first neighbor bonding?

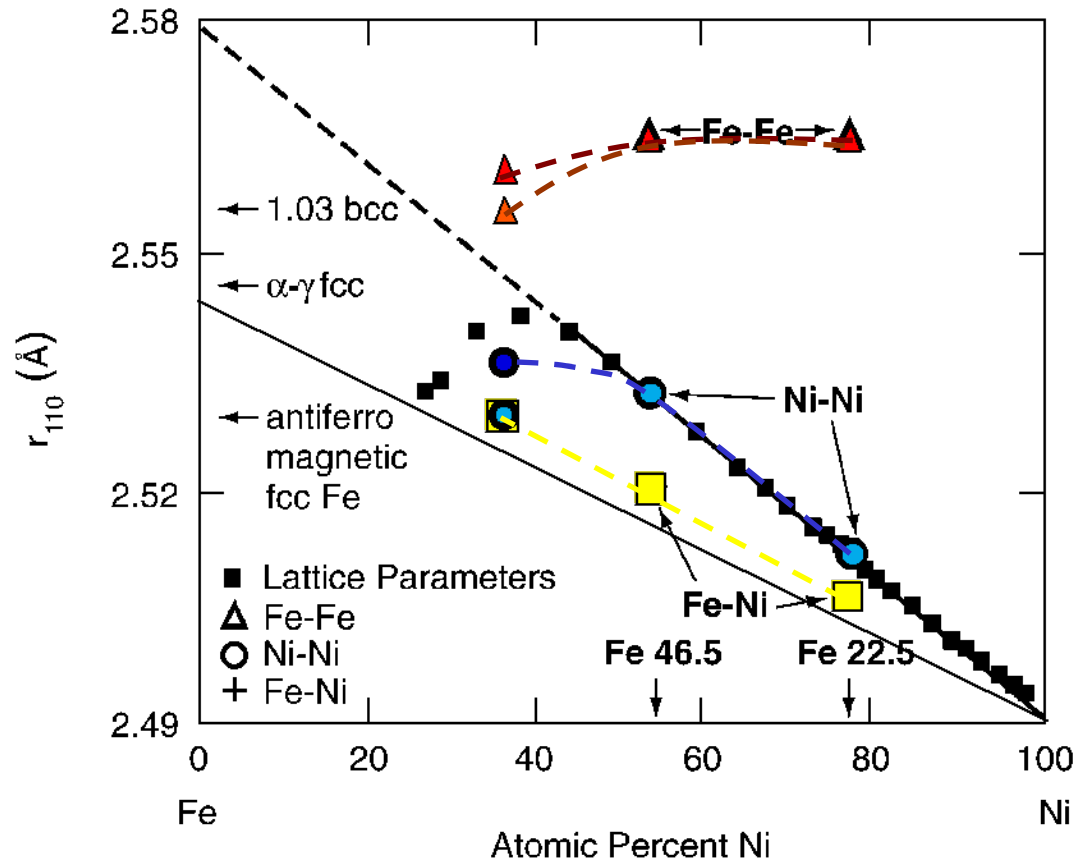

# High-energy x-ray measurements revolutionize studies of phase stability

- Data in *seconds* instead of *days*
- Minimum absorption and stability corrections
- New analysis provides direct link to first-principle

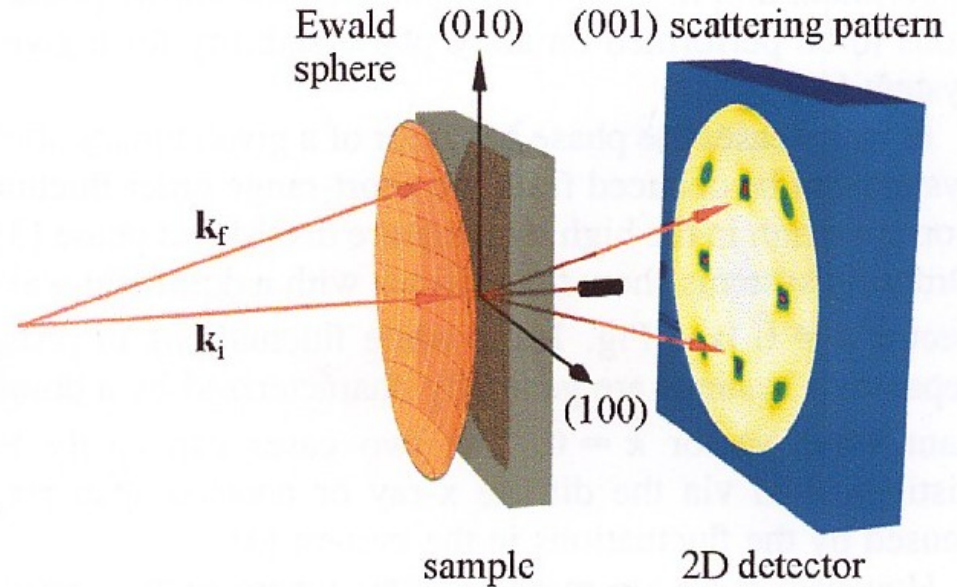

*Max Planck integrates diffuse x-ray scattering elements!*

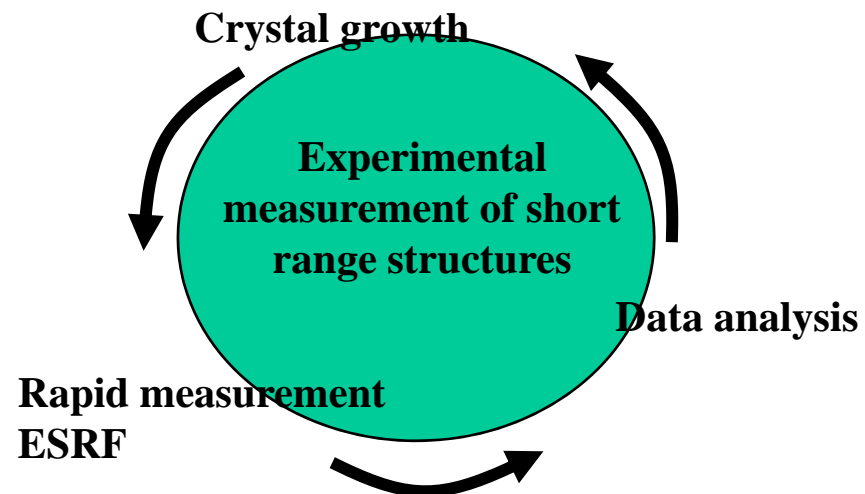

# Measurements show competing tendencies to order

$\text{Au}_3\text{Ni}$  -001 plane

- Both  $L1_2$  and  $Z_1$  present
- Compare with first principles calculations

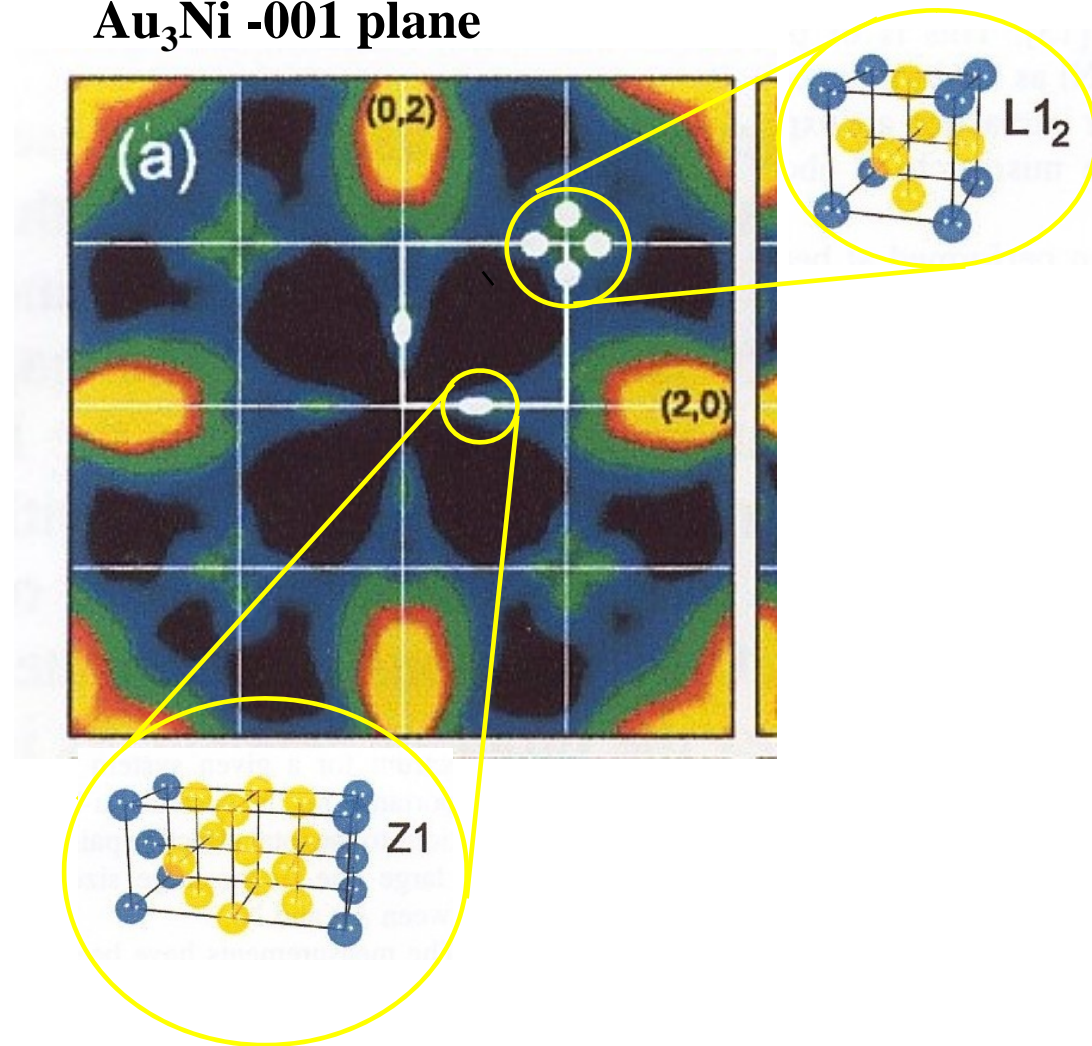
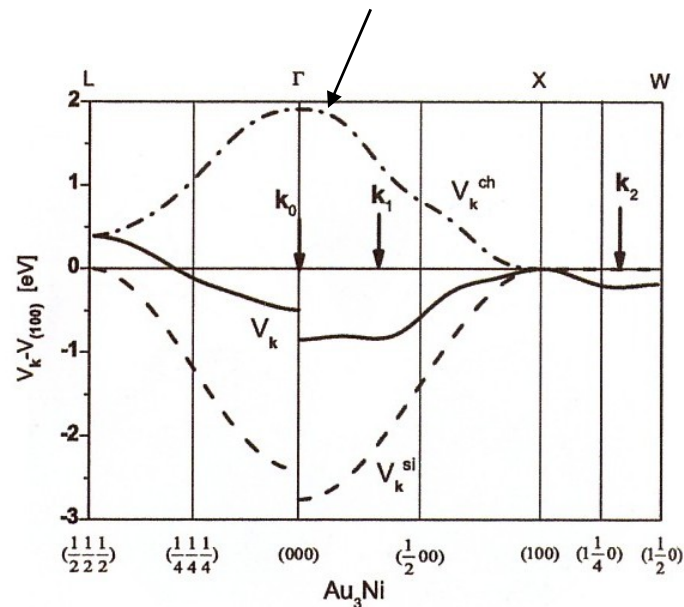

# Intense microbeams/area detectors provide new direction in diffuse scattering

- Tiny crystals ( $20\ \mu\text{m}$ )
  - Natural polycrystals
  - No special sample prep
- Combinatorial
- Dangerous samples

Single-crystal-quality defect characterization

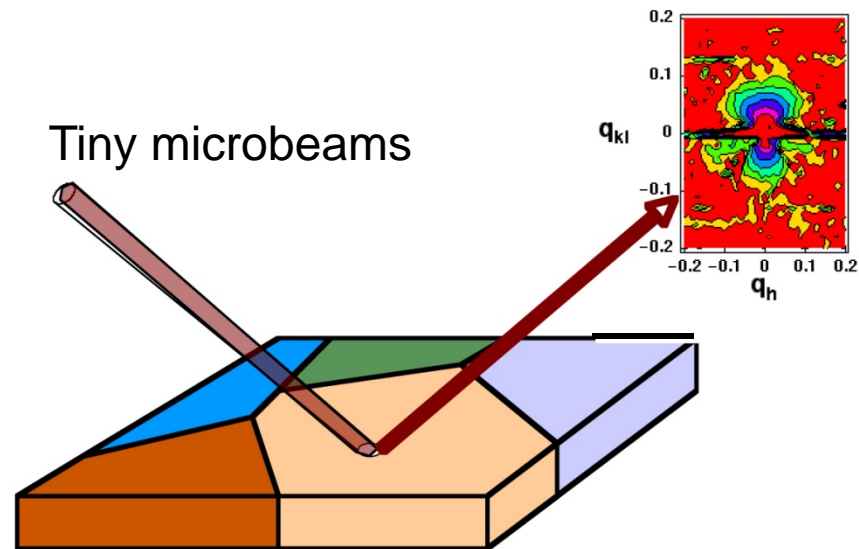

Hazardous *polycrystal* samples



# Small irradiated volumes simplify handling/preparation

- Activity  $\sim$  volume ( $10^{-5}$ )
- Much less waste ( $10^{-7}$ )
- Polycrystalline samples easier obtain-  
*closer to real materials*

Traditional diffuse sample  $\sim 300 \text{ mm}^3$

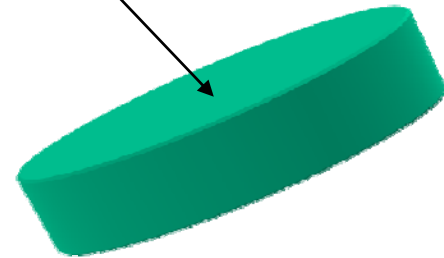

Microsample  $\sim 10^{-3} \text{ mm}^3$   
100-1000 samples

# *Diffuse* microdiffraction holds promise for irradiated materials

- Powerful single crystal techniques applied to polycrystals
- ~4-6 Orders of magnitude lower activity
  - Safer/lower backgrounds
- Cryocooled samples to study initial defects
- New information about point/line/mesoscale defect interactions

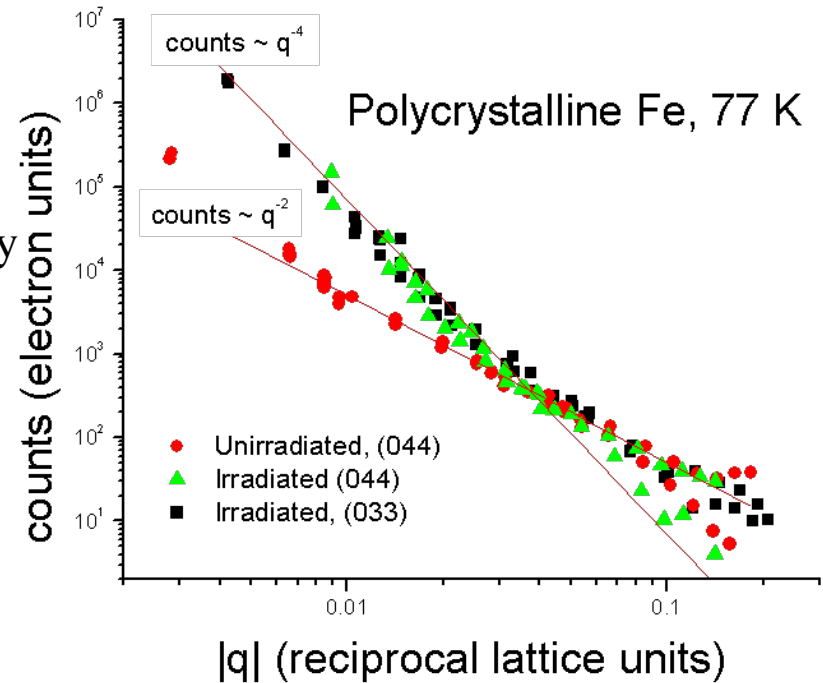

***Successful demonstration experiments!***

# Vacancies, interstitials, small dislocation loops, coherent precipitates are additional type 1 defects

## Lattice Distortions

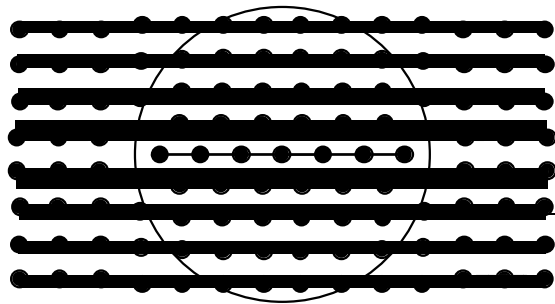
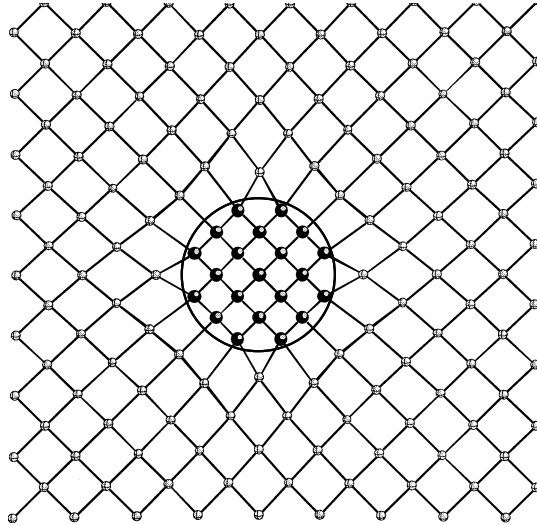

## Coherent Precipitate

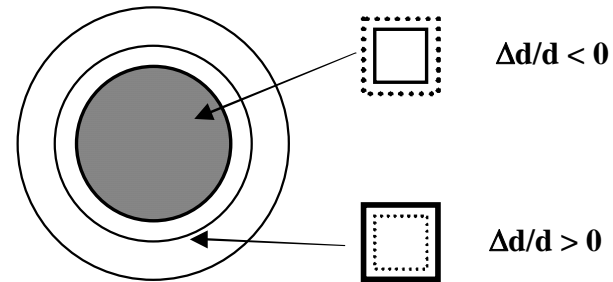

## Dislocation Loop

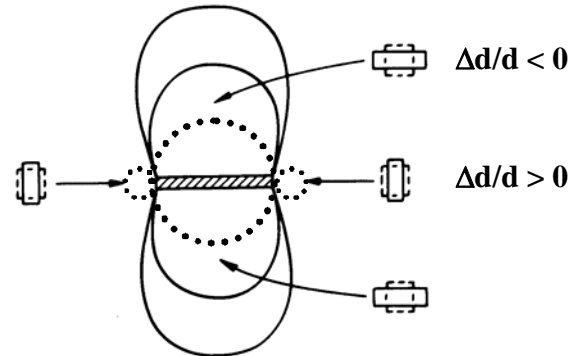

# Numerical calculations determine quantitative cross sections

- Sign of diffuse scattering reverses for vacancy/interstitials
- For interstitial loops- enhanced scattering at  $q=bH/4R$
- For coherent precipitates enhancement at  $q=-\epsilon H$

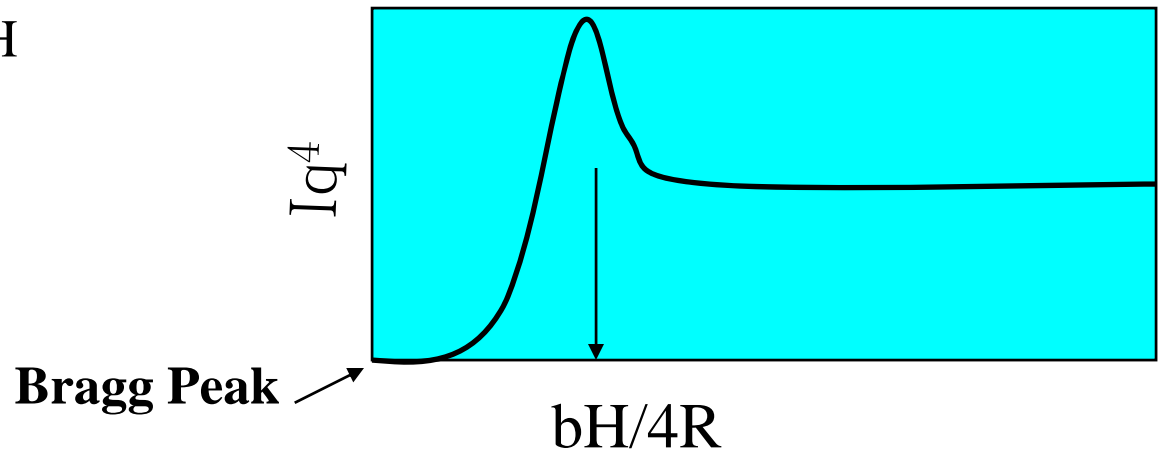
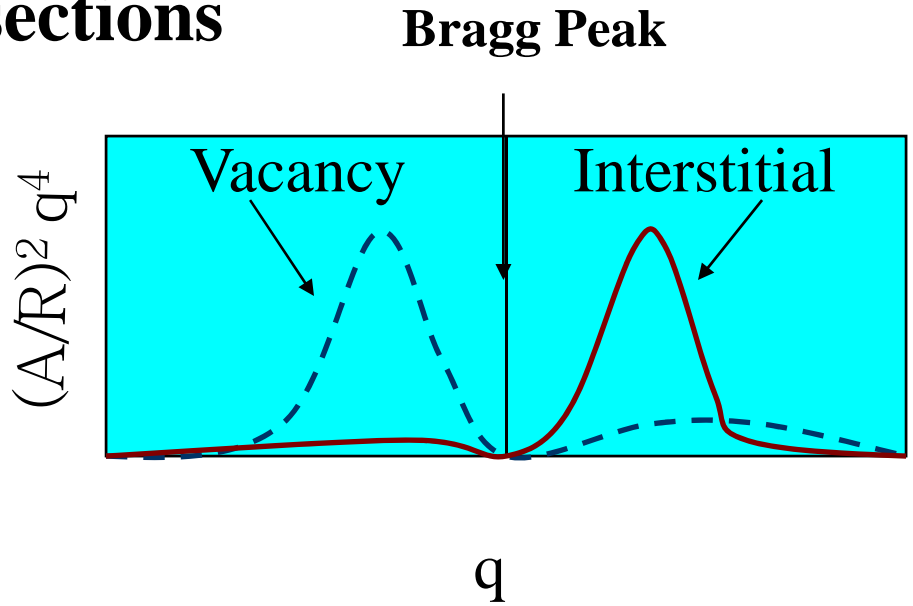

# Micro-diffuse scattering applied to High Energy, Self-Ion Implantation in Si

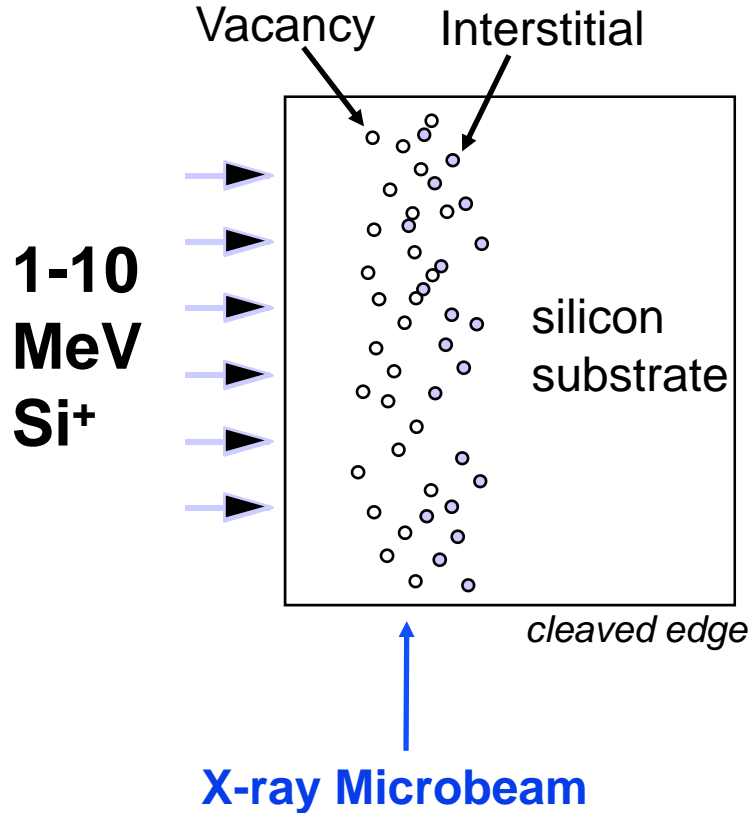

- cleave sample in cross-section
- translate to probe depth dependence

Spatial separation of recoils and vacancies due to momentum transfer

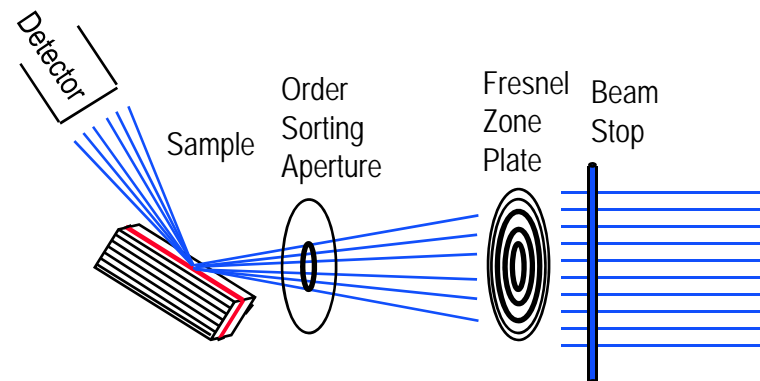
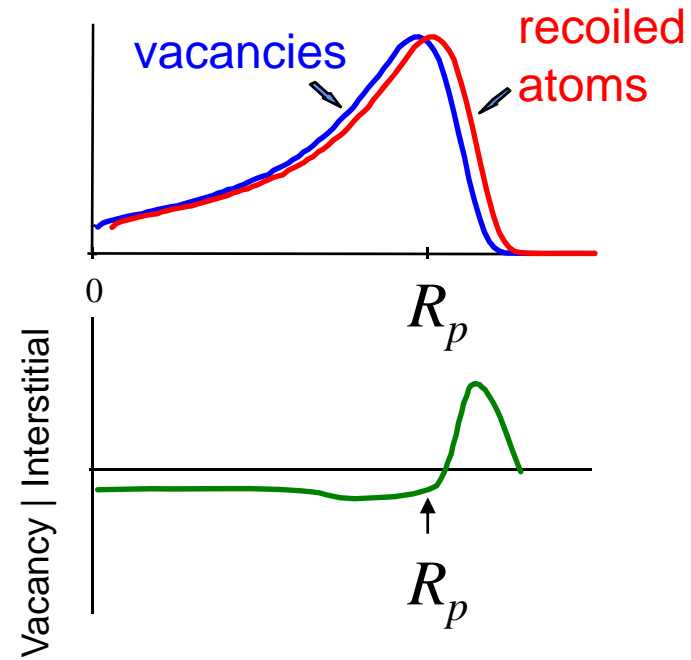

# X-ray Diffuse Scattering

Huang theory  $\Rightarrow$  for  $Q \ll 1/R$ ,  $I \propto Kb\pi R^2/Q^4$

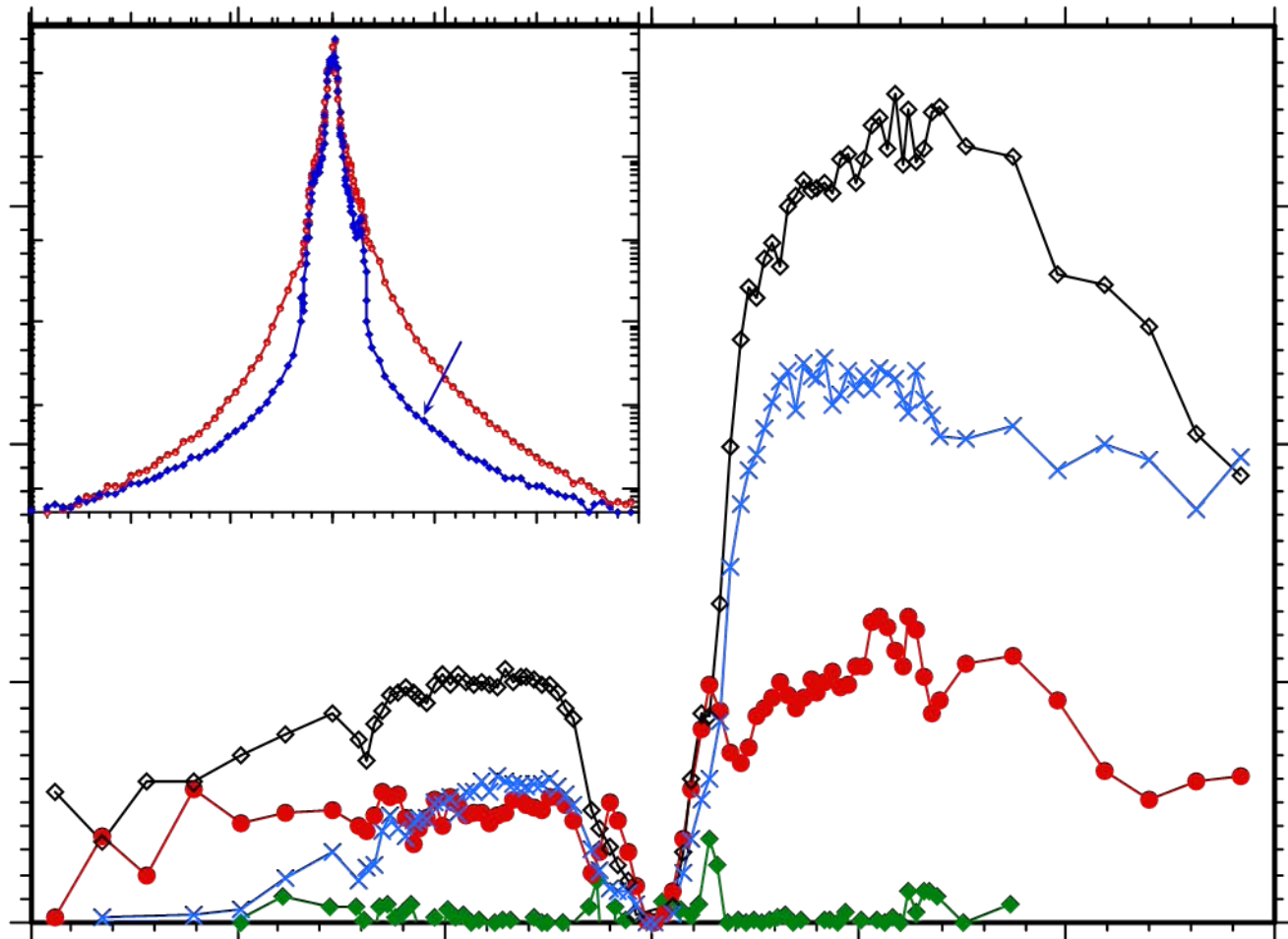

# Depth Dependence of Size Distributions for Ion-Implanted Si

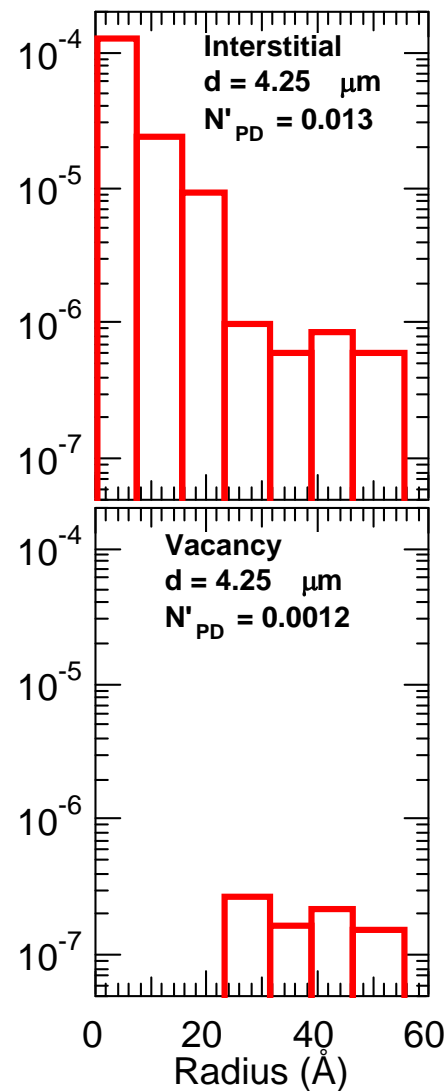
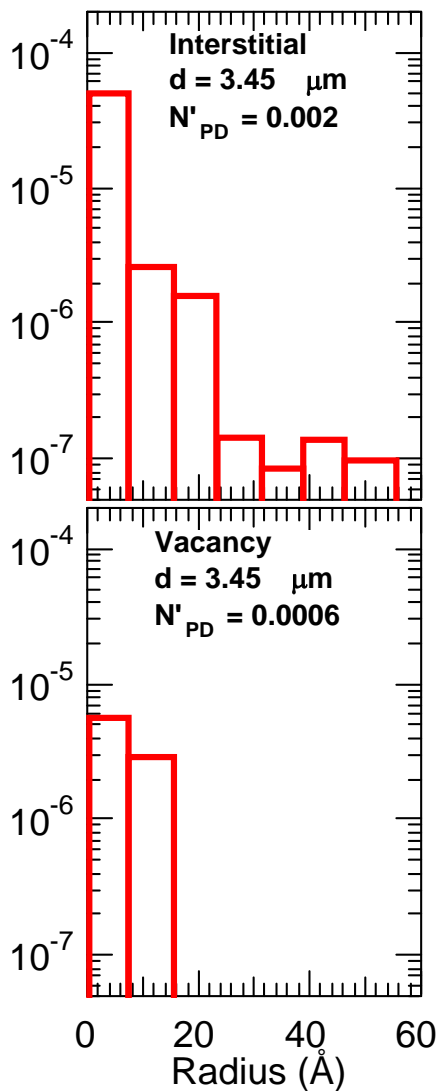
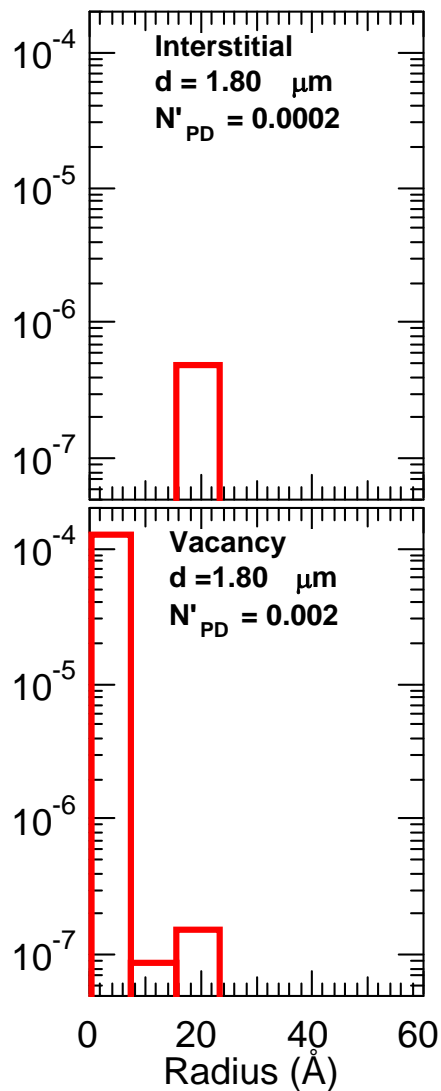

# Corelli SNS beamline specialized for diffuse scattering with elastic Discrimination

- Complex disorder and short-range correlations

QuickTime™ and a  
TIFF (Uncompressed) decompressor  
are needed to see this picture.

QuickTime™ and a  
TIFF (Uncompressed) decompressor  
are needed to see this picture.



# Nondispersive tunable microbeam will measure diffuse scattering without moving

- Tunable beam moves  $<0.5$   $\mu\text{m}$
- Area detector collects data in parallel
- Cooling needed to reduce background
- Must eliminate harmonics

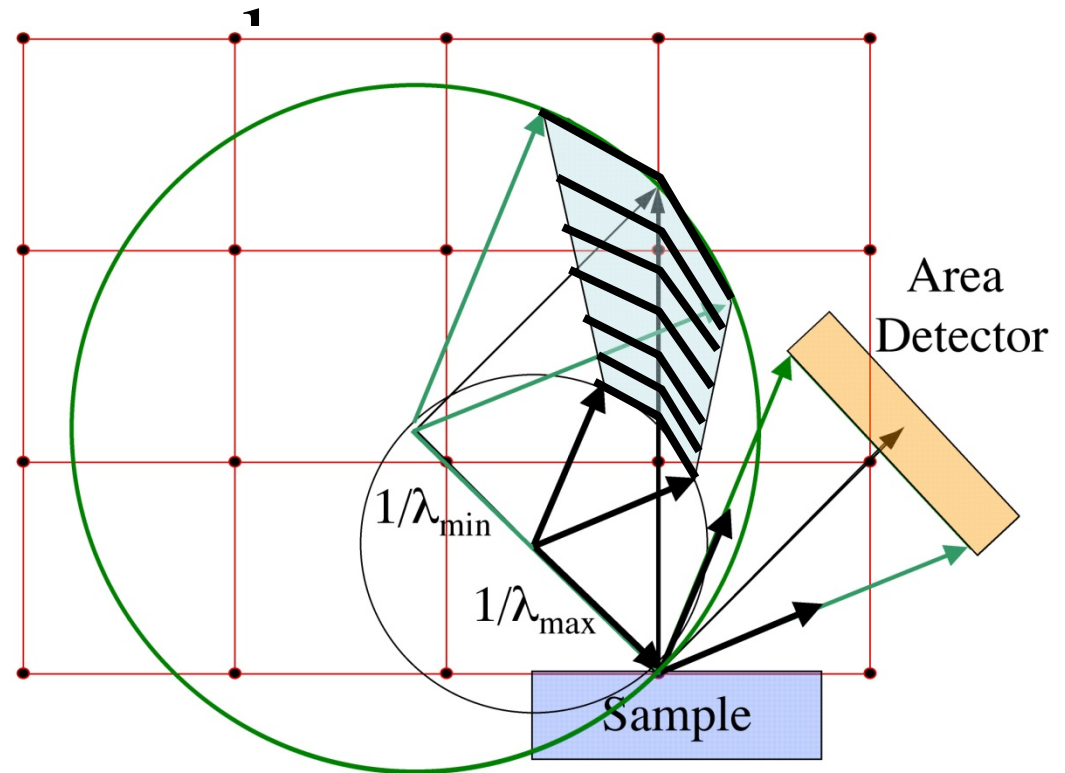

# Dislocations examples of defects of the 2nd kind where microbeams already provide new information

- Long-range effect on lattice sites
- Paired dislocations causes broadening of Bragg peak
- Unpaired causes macroscopic rotations of crystal planes with streaking of reflections

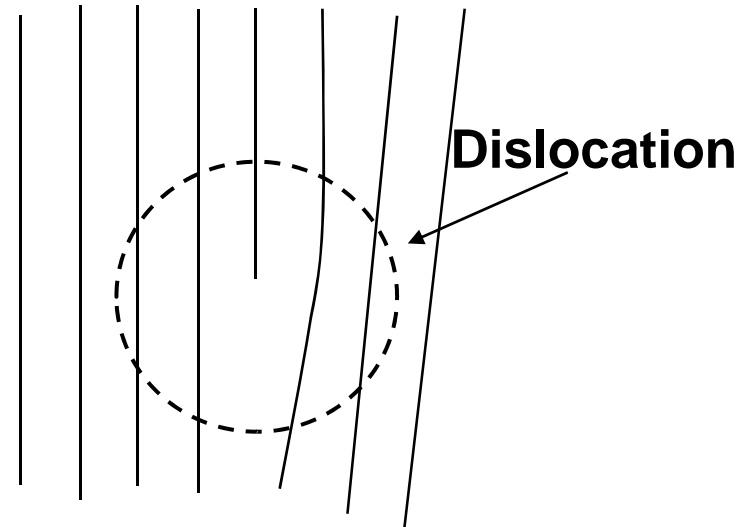

# Influence of number and orientation of dislocations can be quantified

◆= $[1-2-1]$ ,  $n=[-1-11]$ ,  $b=[101]$

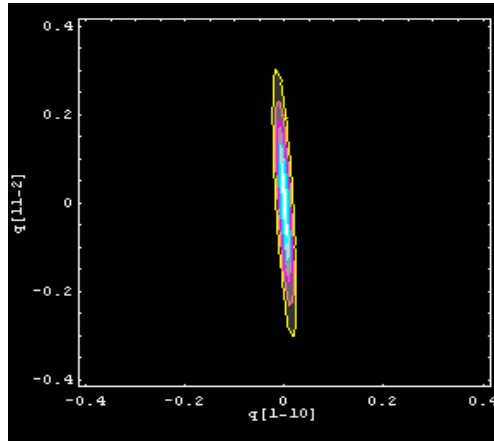

◆= $[-1-21]$ ,  $n=[-111]$ ,  $b=[101]$

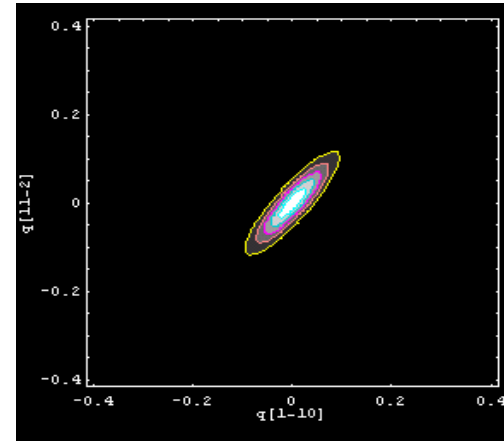

◆= $[-11-2]$ ,  $n=[1\bar{1}1]$ ,  $b=[110]$

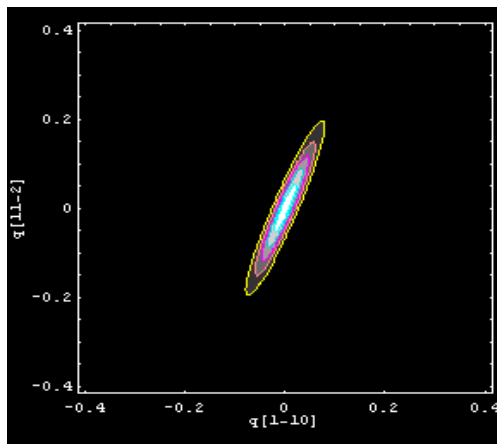

◆= $[1\bar{1}2]$ ,  $n=[1\bar{1}1]$ ,  $b=[110]$

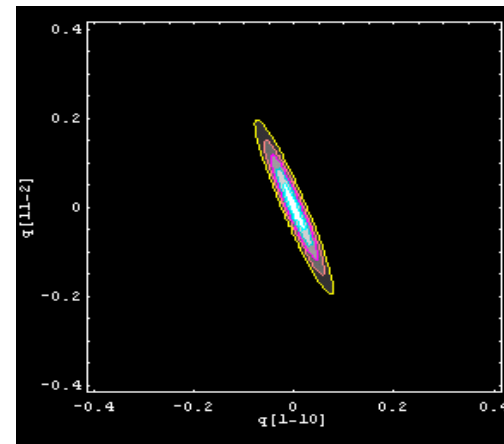

# X-ray diffuse scattering at Femtosecond Resolution

- **Ultra-brilliant LCLS opens new experimental possibilities**
- **Transient behaviors at femtosecond time scales demonstrated.**



QuickTime™ and a  
TIFF (Uncompressed) decompressor  
are needed to see this picture.

**Lindenberg et al. PRL 100 135502 (2008)**

# New directions in diffuse scattering

- High-energy x-ray
- Microdiffuse x-ray scattering
  - Combinatorial
  - Easy sample preparation
- Diffuse neutron data from every sample
- Interpretation more closely tied to theory
  - Modeling of scattering x-ray/neutron intensity

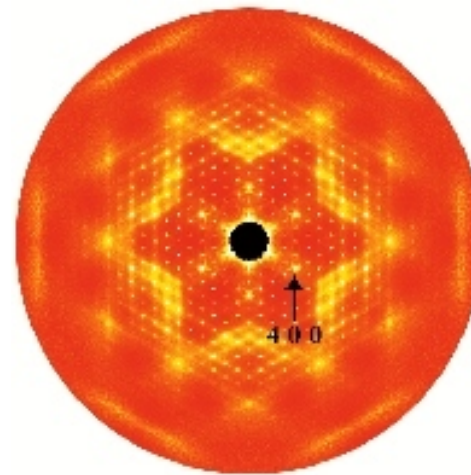
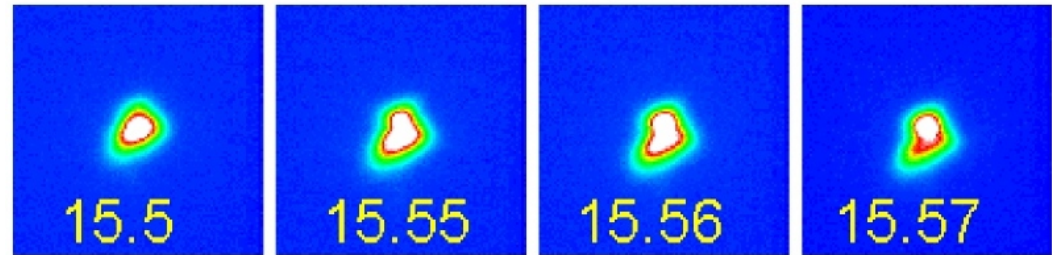

**Experiment**

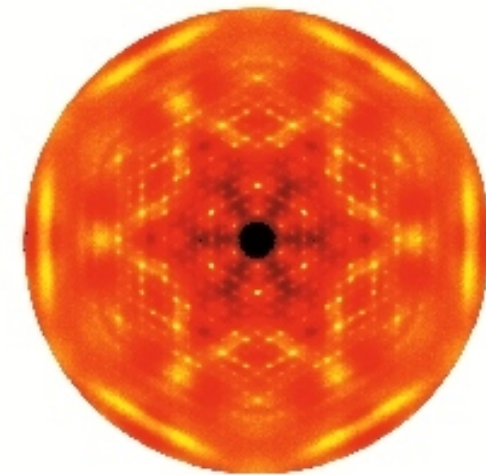

**Model**

# Intense synchrotron/neutron sources realize the promise envisioned by pioneers of diffuse x-ray scattering

- M. Born and T. Von Karman 1912-1946- *TDS*
- Andre Guiner (30's-40's)-*qualitative size*
- I. M. Lifshitz *J. Exp. Theoret. Phys. (USSR)* **8** 959 (1937)
- K. Huang *Proc. Roy. Soc.* **190A** 102 (1947)-*long ranged strain fields*
- J. M Cowley (1950) *J. Appl. Phys.*-*local atomic size*
- Warren, Averbach and Roberts *J. App. Phys* **22** 1493 (1954) -*SRO*
- Krivoglaz *JETP* **34** 139 1958 *chemical and spatial fluctuations*

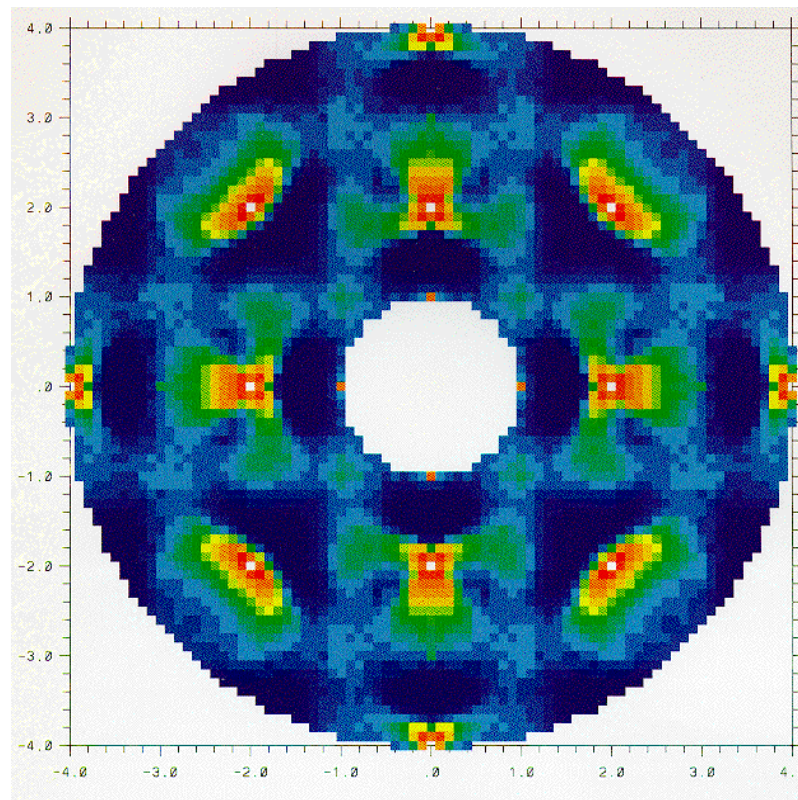

## Other references:

- X-ray Diffraction- B.E. Warren Dover Publications New York 1990.
- [http://www.uni-wuerzburg.de/mineralogie/crystal/teaching/dif\\_a.html](http://www.uni-wuerzburg.de/mineralogie/crystal/teaching/dif_a.html)
- Krivoglaz vol. I and Vol II.



# Diffuse scattering done by small community

- Warren school



S. Cowley, Arizona St.

Bernie Borie, ORNL

Jerry Cohen, Northwestern

B. Schoenfeld, ETH Zurich

W. Schweika, KFA Jülich

Simon Moss, U. Of Houston



Cullie Sparks  
ORNL



A. Gunier

- Krivoglaz school

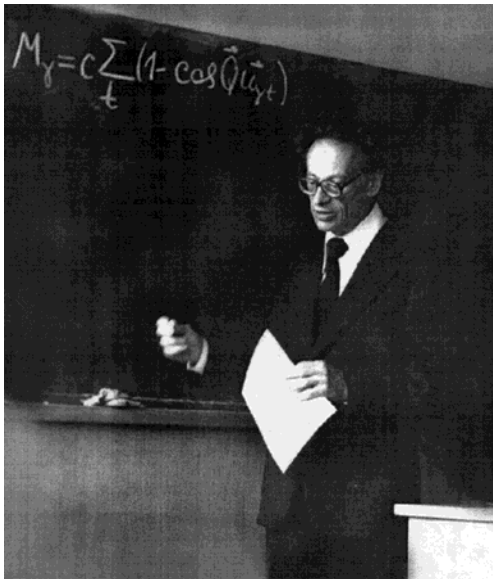

Peisl, U. München

H. Reichert, Max Planck

Gitgarts, Minsk

Rya Boshupka, IMP

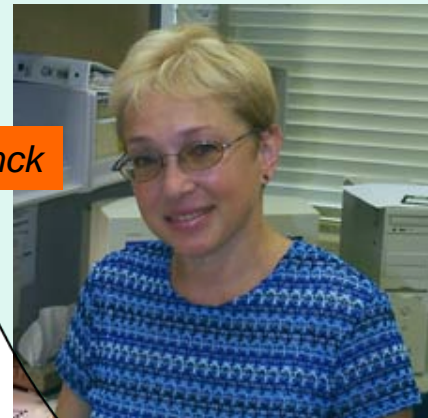

Rosa Barabash  
ORNL

## Diffuse scattering song

Come eager young scholars- so tender and new  
I'll teach you diffraction- what I says mostly true  
Between the Bragg Peaks lies a world where you see  
Fluctuations and defects- they stand out plane-ly

### Chorus

For its dark as a dungeon between the Bragg peaks  
But here in the darkness- each defect speaks  
It gathers- from throughout- reciprocal space  
And re-distributes all over the place.

Between the Bragg peaks - one thing that we see  
Is TDS on our CCD  
Intensity totals are conserved- you can't win  
It steals from the Bragg peaks that stay very thin

Substitutional alloys can cause quite a stir  
The shorter the length scale the greater the blur  
With care you can find out the bond length between  
Each atom pair type-the measurements clean

Dislocations and other- type 2 defects  
Destroy the Bragg peaks -they turn them to wrecks  
But near the Bragg peaks- you still can see  
Intense diffraction continuously

Many -are- the defects you find  
Between the Bragg peaks where others are blind  
So go tell your friends and impress your boss  
You've new understanding -with one hours loss

